



**metro**<sup>®</sup>

Washington  
Metropolitan  
Area  
Transit  
Authority

# Request For Proposal [Federal]

---

## Mechanical Construction Services Multiple Award Task Order Contract (MATOC)

**RFP NO. FQ14114/MDG**

**Date: December 16, 2014**

**Book 2 of 5  
General Requirements**



**SECTION 00011**

**TABLE OF CONTENTS FOR DIVISION 1**

01100 Summary

- 01110 Summary of Work
- 01111 Contractor Key Staff
- 01114 Safety/Environmental Requirements
- 01115 Safety and Security Certification
- 01116 Identification and Security
- 01141 Access to Site

01200 Price and Payment Procedures

- 01250 Contract Modifications Procedures

01300 Administrative Requirements

- 01312 Project Meetings
- 01321 Construction Photographs
- 01322 Contract Progress Reporting
- 01330 Submittal Procedures

01400 Quality Requirements

- 01420 References
- 01470 Quality Management System

01500 Temporary Facilities and Controls

- 01560 Temporary Barriers and Enclosures
- 01570 Temporary Controls
- 01580 Project Signs

01600 Product Requirements

- 01610 Basic Product Requirements
- 01630 Product Substitution Procedures

01700 Execution Requirements

- 01711 Acceptance of Conditions
- 01731 Cutting and Patching
- 01740 Cleaning
- 01775 Closeout

01800 Facility Operation

- 01820 Demonstration and Training

Attachments

- 01114A MSDS Review Request Form
- 01115A Sample Certifiable Items List (CIL)
- 01250A Form C-113 Daily Report – Labor, Materials and Equipment
- 01775A AFC Asset-Parts Template
- 01775A Sample Preventive Maintenance Instruction (PMI)

END OF SECTION



**SECTION 01110**  
**SUMMARY OF WORK**

**PART 1 – GENERAL**

**1.1 SUMMARY**

- A. The Work includes constructing, testing and commissioning the Work of each task issued as indicated in the associated Contract Documents provided for each task.
- B. Provide a diverse range of mechanical construction services including, but not limited to, mechanical equipment demolition, repair, replacement, modification, and addition.
- C. Provide electrical, plumbing, and controls work associated with mechanical equipment and systems.
- D. Provide general construction services incidental to facilities within which the mechanical equipment and systems work is performed including the following:
  - 1. Control of water intrusion into facilities by:
    - a. Sealing cracks, sealing ducts, and performing minor roof repair
    - b. Removing and replacing defective sump pumps and controls
  - 2. Installing water crack injection in concrete walls, floors, and ceilings
  - 3. Repairing and patching of concrete spalls
  - 4. Cutting openings and sealing openings in concrete and masonry walls
  - 5. Window and door removal and installation, including finish hardware
  - 6. Carpentry
  - 7. Painting
  - 8. Demolishing and removing materials associated with general construction services
- E. All finished Work shall function as an integral part of and be fully compatible with the existing WMATA system.
- F. Work will not include architectural/engineering services unless specifically requested.
- G. Drawings included in these Contract Documents serve as a Seed Project to provide an indication of one type of work that will be performed by the successful Contractors when tasks are issued. The Seed Project includes Tiebreaker Station (TBS) and Traction Power Substation (TPSS) upgrades at three locations. Upgrades consist of mechanical equipment and associated electrical equipment removal and disposal, installation of mechanical equipment, controls, and associated electrical work, and water intrusion remediation, all as indicated in the Contract Drawings.

**1.2 CONDITIONS**

- A. The Work will be issued to each of the selected Contractors through a series of tasks.
- B. Summary of Work, a set of Contract Drawings and applicable specifications will be provided by the Authority for each task. Special Conditions and General Requirements not already defined in this Contract will be provided with each task.

### 1.3 DAYS/HOURS OF WORK

- A. Working hours for each Seed Project work site are Monday through Friday, 8 AM to 5 PM.
- B. Provide Contracting Officer Representative 7 Days advance notice prior to changing shift hours and 48 hours advance notice for planned work shifts outside the established work week and work day.

### 1.4 LOCATION

- A. The Project locations are in the Washington Metropolitan Area. Specific Sites for this Task are shown in the Contract Documents.

### 1.5 SITE LOGISTICS

- A. Access to the construction Sites shall be as defined in the Contract Documents.
- B. Contractor is responsible for off-site storage and staging until equipment and materials can be delivered to the facilities being upgraded.
- C. Staging is prohibited in the public areas and roadways.
  - 1. Contractor shall be staffed to support up to three locations simultaneously and have adequate staff to support each shift.
- D. Parking
  - 1. WMATA will not provide Contractor parking.
- E. Constraints on Construction
  - 1. Work Sequence
    - a. Perform field measurements and surveys to field verify space, clearances, access openings, hatches, doors, and other means of access to the facilities where work is to be performed.
    - b. Perform field measurements and surveys of existing equipment prior to ordering equipment to verify damper sizes, circuit breakers, starters, ductwork, automatic temperature control panels and devices, alarm devices and connections, and remote alarm contacts.
    - c. Perform baseline tests for mechanical equipment to remain and submit test reports in accordance with Section 01330, SUBMITTAL PROCEDURES, to identify deficiencies in existing systems that require repair.
    - d. Construction shall be completed in coordination with the Authority's rehabilitation construction schedule and concurrent construction contracts.
  - 2. Special Events
    - a. Construction activities shall be coordinated with the special events supported by the Authority, as noted in Section 01141, ACCESS TO SITE.
    - b. Maintain a Special Community Event List in coordination with the Authority for the duration of the Contract. The list shall identify local special holidays, parades, festivals, and other similar events that are within the proximity of the Project construction areas and operations. The list shall include the following information:
      - (1) Name and general description of the event

(2) Date, time of day, and duration

(3) Location(s)

F. Work performed by Authority

1. Authority will provide a Prime Mover and standard flat car with operator to assist Contractor in removing existing equipment and materials from facilities and delivering equipment and materials to facilities for locations that are only accessible by rail. This support will be provided once per location to remove existing material and once per location to deliver material. Any other rail equipment required for equipment and material removal and delivery shall be the responsibility of the Contractor. Contractor-provided rail equipment requires Authority approval and inspection prior to use.

G. Coordination of Work with Others: Coordinate Work through the Contracting Officer Representative with the following:

1. Jurisdictional Authorities affected by or having jurisdiction over the Projects.
2. Contractor shall coordinate work at each facility with Authority contractors (others) performing work in the same facility through Contracting Officer Representative.

H. Survey Work: Perform as needed to execute the Project as specified.

I. Permits: Obtain permits from Jurisdictional Authorities as needed.

J. Safety: Establish and manage Project safety in accordance with Section 01114, SAFETY/ENVIRONMENTAL REQUIREMENTS, and safety and security certification in accordance with Section 01115, SAFETY AND SECURITY CERTIFICATION.

K. Quality: Establish and manage a Quality System in accordance with Section 01470, QUALITY MANAGEMENT SYSTEM.

L. Inspection and Testing

1. Ensure that construction is being performed in accordance with Contract Documents and applicable Submittals.
2. Establish and perform component testing and system integration testing as specified in various specification sections and in accordance with Section 01470, QUALITY MANAGEMENT SYSTEM. Develop and implement a testing plan for Authority review.

M. As-Built Documents: Maintain a hard copy drawing and specification record of as-built conditions during construction phase, and provide As-Built Drawings and As-Built Specifications at the completion of the Project in accordance with Section 01775, CLOSEOUT.

N. Training and Commissioning: Provide support for commissioning in accordance with Section 01470, QUALITY MANAGEMENT SYSTEM, Section 01775, CLOSEOUT, and provide training to WMATA staff as indicated in Section 01820, DEMONSTRATION AND TRAINING.

O. Salvaging of Materials and Equipment

1. Maintain property control records for materials or equipment to be salvaged. The Contractor shall be responsible for the storage and protection of salvaged materials and equipment and shall replace salvaged materials and equipment, which are broken or damaged during salvage operations as the result of negligence or while in the Contractor's care.
2. Salvaged material not specified for reuse shall become the property of the Contractor and shall be removed from the Site.

3. Materials or equipment shall to be salvaged for reuse:
  - a. Refer to Contract Drawings for materials to be reused and salvaged.

PART 2 – PRODUCTS (not used)

PART 3 – EXECUTION

3.1 FIELD QUALITY CONTROL

A. Field Testing and Inspection

1. General

- a. Conduct field testing and inspection at each Site to ensure proper operation of equipment provided.
- b. Correct deficiencies found during field testing and retest at no additional cost to the Authority.

2. Field Inspection

- a. Prior to field testing, check equipment installation in accordance with manufacturer's recommendations and applicable codes. Verify the following:
  - (1) Tightness of connections
  - (2) Ensure equipment and panels are labeled in accordance with Contract Drawings.

3. Field Testing

- a. Coordinate with the Contracting Officer Representative to establish the specific testing schedule for each facility. Notify the Contracting Officer Representative 1 week in advance of each test. Conduct test in presence of Contracting Officer Representative.
- b. Furnish test equipment, labor, and services of Contractors' representative to perform specified tests.
- c. Submit test reports within 10 days of Substantial Completion Inspection (SCI). For each item, submit for approval and perform approved tests but not limited to those specified.

3.2 IDENTIFICATION

- A. Label equipment and panels in accordance with Contract Drawings and Specifications.

END OF SECTION



**SECTION 01111**  
**CONTRACTOR KEY STAFF**

**PART 1 – GENERAL**

**1.1 SUMMARY**

- A. This Section specifies key staff that forms the Contractor's team and identifies their basic functions.

**1.2 REFERENCES**

- A. Registrar Accreditation Board of the American Society for Quality (RABASQ)
- B. Occupational Safety and Health Association (OSHA)
  - 1. Construction Safety Training
  - 2. First Aid/CPR/Blood Borne Pathogens Training

**1.3 SUBMITTALS**

- A. Submit the following with technical proposal or as noted in accordance with Section 01330, SUBMITTAL PROCEDURES:
  - 1. Evidence of qualifications and experience of Key Staff to include references from last three employers
  - 2. Foreman: Evidence of attainment of the position of Foreman for each Foreman assigned to a Task within 10 days of assignment of each Task.

**1.4 CONTRACTOR**

- A. The Contractor shall be responsible for constructing the Project and for furnishing the services of Subcontractors and vendors, to perform all manufacture, fabrication, installation, and construction to complete the Project in accordance with the Contract Drawings and Contract Specifications issued for each Task, all applicable jurisdictional codes and regulations, the approved Quality Management System; the approved Safety Plan; and environmental and other applicable requirements to achieve Acceptance in accordance with the approved Project Schedule. The Contractor shall obtain jurisdictional approvals and permits, and Utility approvals.
- B. All personnel involved in the performance of construction work shall be experienced and qualified to perform their trade, and all construction work shall be performed in a skilled and workmanlike manner.
- C. All Key Staff shall be full time staff during the times that tasks are assigned and being executed by the Contractor.
- D. Contracting Officer Representative reserves the right reject any Key Staff that do not meet the required qualifications.
- E. Individuals holding these key staff positions shall not be changed without written Authority approval for substitutions of key staff.

- F. Key Staff shall be supported by a SSWP/Track Access Coordinator having the required level of skill to deliver the Project in accordance with the Contract Documents and the approved Project Schedule.
- G. Key Contractor Staff
  - 1. Project Manager
    - a. Shall have a minimum of 5 years experience in mechanical contracting, equipment installation and system commissioning; a minimum of 2 years in the rapid transit industry; and a minimum of 5 years in a supervisory capacity on projects of similar type and financial magnitude.
    - b. Responsible for managing all facets of the Project and has overall responsibility for its successful and timely completion. Supervises the Key Staff, shall be the sole point of contact with the Contracting Officer Representative, shall be responsible for coordinating with outside agencies as required, shall be responsible for managing cost and maintaining schedule of the Project, shall be responsible for ensuring that QA/QC and Safety guidelines are followed, and shall be responsible for testing, commissioning, and close-out of the Project. Responsibilities include but are not limited to acquiring and managing Subcontractors, fabricators and Suppliers; development, management, and implementation of Project Schedule; preparation, submittal, and management of submittals; maintaining as-built documentation; and coordinating with outside agencies on construction related matters.
    - c.
  - 2. Construction General Superintendent
    - a. Shall have a minimum of 10 years experience in mechanical equipment installation, associated work as described in Section 01110, SUMMARY OF WORK, and system commissioning, a minimum of 2 years in rapid transit industry, and a minimum of 5 years in a supervisory capacity supervising projects of a similar type and financial magnitude.
    - b. Responsible for oversight of day-to-day demolition, equipment installation, testing, and commissioning at each Site.
    - c. Responsibilities include but are not limited to supervising construction activity, overseeing coordination between Subcontractors, coordinating with Quality Manager and Safety Manager in the implementation of Project Quality and Safety plans, and ensuring that construction is based on current Shop Drawings and Working Drawings. The Construction General Superintendent is also responsible for maintaining as-built documentation.
  - 3. Quality Manager
    - a. Shall be trained as a Lead Auditor in a Registrar Accreditation Board of the American Society for Quality (RABASQ) approved course on the requirements of ISO 9001 and with a minimum of 5 years of related experience including a minimum of 2 years of management positions in a production, manufacturing, or construction environment performing QA/QC auditing. Transit industry experience is preferred.
    - b. Reports to one or more levels of management above the Contractor's Project Manager.
    - c. Responsible for the Quality Assurance (QA) and Quality Control (QC) for the Project and shall be fully familiar with the Federal Transit Agency's (FTA) Quality requirements.
    - d. Shall be a staff member of the Contractor and shall establish, implement, and maintain the Quality Management System, shall report directly to and be supervised by an Officer of the Contractor at a level above that of the Project Manager responsible for the Project,

shall serve as a liaison officer with the Authority and the Jurisdictional Authorities on matters relating to the Contractor's quality system, shall be responsible for ensuring that the Quality Management System is effective in ensuring that the Contract requirements are satisfied, and shall be responsible for the oversight of onsite and offsite testing by the Contractor.

- e. The Quality Manager may be approved as the Safety and Security Certification Manager as defined in Section 01115, SAFETY AND SECURITY CERTIFICATION.

4. Safety Superintendent

- a. Shall have a minimum of 15 years experience in heavy industry construction safety practices and with a minimum of 5 years in rapid transit construction in operating conditions, and shall have completed OSHA Construction Safety Training and First Aid/CPR/Blood Borne Pathogens Training. Shall be a Certified Safety Professional (CSP).
- b. Responsible for development of a construction safety plan.
- c. Shall be a member of the Contractor and devoted to worksite safety in implementing, enforcing, and maintaining the safety program for the Contractor and Subcontractor forces. The Safety Superintendent shall have no duty other than safety supervision of persons, equipment, and property affected by Contract work.
- d. Shall have specialized training and experience in construction safety supervision and have a thorough knowledge of all OSHA regulations. The Safety Superintendent shall have the ability to develop and conduct safety-training courses. The Safety Superintendent shall be familiar with industrial hygiene equipment and testing as required for the protection of all personnel and the public.

5. Foreman/Foremen

- a. Shall have a minimum of 5 years experience working with mechanical systems and associated work as described in Section 01110, SUMMARY OF WORK, and 2 years with oversight of a crew of no less than six.

PART 2 – PRODUCTS (not used)

PART 3 – EXECUTION (not used)

END OF SECTION

## SECTION 01114

### SAFETY/ENVIRONMENTAL REQUIREMENTS

#### PART 1 – GENERAL

##### 1.1 SUMMARY

- A. This Section includes construction safety and security and environmental safety requirements for the Project including WMATA's Safety Awareness Program.

##### 1.2 REFERENCES

- A. WMATA Construction Safety and Environmental Manual (CSEM)
- B. ANSI/ISEA 107 - American National Standard for High-Visibility Safety Apparel
- C. Occupational Safety and Health Association (OSHA)
  - 1. 29 CFR §1910
  - 2. 29 CFR §1926
  - 3. 49 CFR §172
  - 4. 49 CFR §390-397
- D. U.S. Army Corps of Engineers - Safety Manual EM-385-1-1
- E. National Commission for the Certification of Crane Operators
- F. Resource Conservation and Recovery Act (RCRA) of 1976 and amendments
- G. Metrorail Safety Rules and Procedures Handbook (MSRPH) - SOP #19, #28, #39, #41 and #49
- H. WMATA, Office of Rail Transportation Maintenance Operations Control, Administrative Procedure OAP 200-33, Site Specific Work Plan (SSWP)

##### 1.3 QUALITY ASSURANCE

- A. Safety Superintendent: As specified in Section 01111, CONTRACTOR'S KEY STAFF
- B. First Aid Attendant
  - 1. Shall have current First Aid and CPR certification. A resume, certifications, and evidence of training shall be submitted documenting education and experience.
  - 2. Shall be trained in Blood-borne Pathogens in accordance with CFR §1910.1030.

##### 1.4 SUBMITTALS

- A. Submit to the Contracting Officer Representative for approval in accordance with Section 01330, SUBMITTAL PROCEDURES, 60 Days prior to commencing construction, unless noted otherwise:
  - 1. Documentation and Certifications of Safety Superintendent's and First Aid Attendant's, as applicable, experience in construction safety.



with SOP No. 19 contained in the Metrorail Safety Rules and Procedures Handbook and OAP 200-33 (SSWP). All special requests for access, single tracking, power outages, escorts, and other Authority support shall be submitted in writing. Site Specific Work Plans shall be submitted for all Work conducted in Authority Right-of Way and any operational facility. Ensure that personnel complete safety training by Authority on the rules and procedures for working on the Right-of-Way before starting such work.

- G. Employ and assign to the construction work a Safety Superintendent as specified in Section 01111, CONTRACTOR KEY STAFF, and a separate certified First Aid Attendant for on-site work activities. A first aid station shall be established and fully equipped to meet the needs of the anticipated work force. The certified First Aid Attendant shall be on duty in the first aid station at all times when construction work is in progress except when on emergency calls. In no event shall work at the Site be performed until the approved Safety Superintendent and First Aid Attendant are available to the Project.
- H. If, at any time, the Work Site is without the services of an approved Safety Superintendent and First Aid Attendant for a period of 15 Days or more, the Work may be closed down at the discretion of the Contracting Officer Representative. The Safety Superintendent and First Aid Attendant shall be acceptable to the Contracting Officer Representative, and their performance will be reviewed and documented by the Contracting Officer Representative on a continuing basis. If the Safety Superintendent's and First Aid Attendant's effectiveness is below standard, the Contractor shall provide immediate replacement at the Contracting Officer Representative's direction. Once employed, the Safety Superintendent and First Aid Attendant shall not be changed without permission of the Contracting Officer Representative.
- I. For all work within Confined Spaces, comply with all OSHA, state, and local Jurisdictional Authority rules and regulations for confined spaces defined by 29 CFR §1910.146. Confined spaces shall be classified as either non-permit confined space or permit-required confined space in accordance with OSHA regulations.
- J. Prior to the initial entry into a confined space, coordinate entry with the Contracting Officer Representative and take air quality readings to establish base readings and conditions. At a minimum, oxygen, lower explosive limit, carbon monoxide, and hydrogen sulfide, shall be measured. Measurement of additional parameters may be required depending on the location of the space and potential for atmospheric hazards related to contamination or work activities.
- K. Air quality and any additional parameter reading results shall be provided to the Contracting Officer Representative for recording purposes and shall determine if atmospheric hazards exist, which would classify the space as a permit-required confined space. Continuous and follow-up monitoring of air quality shall meet OSHA requirements, and all subsequent results shall be provided to the Contracting Officer Representative.
- L. Prior to the start of any work involving non-permit confined spaces, submit the following:
  - 1. Written Job Hazard Analysis for all work to be performed in the confined space, including MSDSs for chemicals to be used in the space. Submit MSDSs for all chemicals to be used on Authority property along with a brief description of how and where they will be used and if wastes will be generated. The MSDSs will be reviewed by Authority and if approved, the materials can be used in the system. If they are rejected, submit a substitute for Authority approval. The MSDSs must be recent (less than 3 years old) and comply with the OSHA Hazard Communication Standard 29 CFR §1910.1200. The Contractor is responsible for complying with the requirements of the MSDSs.
  - 2. Written Emergency Response Plan, which identifies emergency responders for rescue operations.
  - 3. Written plan for a temporary Fire Protection System as specified in Section 00740, PROTECTION OF PERSONS AND PROPERTY, for use during the term of the Contract, for

- Authority approval. Ensure that work activities do not adversely impact existing fire protection system(s) i.e., sprinklers, stand pipes, and portable extinguisher.
4. Identification of air monitoring devices that will be used to monitor air quality at the work Site. Provide copies of most recent manufacturer calibration and all Contractor field calibration checks. As a minimum, Authority requires field calibration checks on air monitoring instruments, each day (or shift) before use. The field calibration check information shall include the date, time, calibration check data, and the printed name and signature of the person performing the calibration check.
  5. Documentation to show that all personnel working in or near non-permit confined spaces are trained in Confined Space Awareness.
- M. Prior to the start of any work involving permit-required confined spaces, submit the following in addition to those items required for non-permit confined spaces:
1. Written Site-specific Confined Space Program.
  2. Confined space permit for applicable space. Each permit is valid for a maximum of 24 hours.
  3. Written Respiratory Protection Program.
  4. Documentation to show that all personnel required to wear respiratory protection have received respiratory protection training, have been fit tested for the respirators they are required to wear (applies to tight fitting respirators) and have been medically evaluated to verify that they have no health problem that would interfere with their safe use of a respirator.
  5. A warning sign to identify the work Site as a permit-required confined space requiring authorization to enter.
  6. The Contractor is required to notify the State at least 24 hours prior to entering permit-required confined spaces or to employ State certified Safety personnel who will manage permit-required confined space access and who will perform the required record keeping.
- N. Provide a Job Hazard Analysis prior to the start of each phase of work.
- O. Work clothing consists of long pants, shirts with long or short sleeves, sturdy work boots, and appropriate personal protective equipment. Jewelry that hangs, loose clothing, or clothing with non-detachable hoods, drawstrings, or anything that can become entangled in machinery, shall not be worn on the work Site if machinery is in use on the work Site. Personal protective equipment such as hard hats and footwear shall meet the requirements of 29 CFR §1910.135 and §1910.136. Athletic-type footwear shall not be worn on the Site.
- P. Smoking is prohibited in the Metrorail system, Metrobus system, other Authority facilities, and in Authority vehicles. The Contracting Officer Representative will select a designated smoking area outside the system or facilities and Contractor will be informed of its location. Contractor personnel found smoking in un-designated areas will be subject to removal from Authority property. The Contractor's Safety Superintendent shall be responsible for ensuring compliance.
- Q. The OSHA Standard for Sanitation, 29 CFR §1910.141, shall be followed. Prior to starting work, furnish for the Contractor's staff, necessary toilet convenience secluded from public view. They should be kept in a clean and sanitary condition and shall comply with the requirements and regulations of the area in which the work is being performed. Potable drinking water shall be provided with individual cups and sanitary conditions for the water dispenser shall be maintained. A common drinking cup and other common utensils are prohibited.
- R. For all work at heights above 6 feet, submit a detailed, site-specific Fall Protection Plan. Comply with the most stringent OSHA requirements for Walking-Working Surfaces (29 CFR Part 1910

- Subpart D), Scaffolds (29 CFR Part 1926, Subpart L), and Fall Protection 29 CFR Part 1926, Subpart M.
- S. Comply with 29 CFR §1910.95, Occupational Noise Exposure for all work on Authority property, including construction. This standard requires that employees exposed to continuous noise in excess of the OSHA Action Level, participate in a Hearing Conservation Program. Instruments used for noise measurements must be appropriate for the type of noise being measured (impact/impulse or continuous).
  - T. If the Work involves removal of paints or coatings, test the paint or coatings to determine if they contain heavy metals such as lead that require special handling and disposal considerations. As a minimum, testing shall be conducted for the eight metals (arsenic, barium, cadmium, chromium, lead, mercury, silver, and selenium) required by the Resource Conservation and Recovery Act (RCRA) of 1976 and amendments. If any of these are present, the components will require special handling and disposal to prevent exposure to workers, patrons, the community, and the environment. The Contractor's personnel performing lead-based paint abatement, removal, or control, shall have all licenses and accreditation required by the jurisdiction in which the work is performed. Jurisdictions that do not have their own state lead plans fall under the auspices of the Environmental Protection Agency (EPA). The Contractor shall provide medical monitoring to meet the requirements of 29 CFR §1910.1025 and §1926.62. As a minimum, medical monitoring shall consist of biological monitoring for lead and zinc protoporphyrin and shall include a physician's medical determination. As a minimum, biological monitoring shall be conducted immediately prior to working on Authority property where the employee may be exposed to lead, and immediately upon completion of this work. The Contractor shall provide training for lead workers and supervisors as required by the jurisdictional regulations. Documentation shall be submitted to the Contracting Officer Representative prior to commencement of work. All documentation shall be authentic and verifiable. All materials shall be handled and disposed of in compliance with the jurisdictional regulations. MSDSs for replacement paints/coatings must be approved by Authority prior to use on Authority property.
  - U. If the Work involves removal of insulation, flooring, cove base, mastic, ceiling tile, roofing materials, or any other material that is suspected of containing asbestos, the Contractor must have the materials sampled and analyzed to determine if they contain asbestos. If the Contractor will be handling or removing asbestos-containing materials, the Contractor shall have all licenses and accreditations required by the jurisdiction in which the work is performed. The Contractor is required to provide medical monitoring to meet the requirements of 29 CFR §1910.1001 and §1926.1101. The Contractor shall provide training for asbestos workers and supervisors as required by the jurisdictional regulations. Documentation shall be provided to the Contracting Officer Representative prior to commencement of work. All documentation shall be authentic and verifiable. All materials shall be handled and disposed of in compliance with the jurisdictional regulations. All replacement materials shall be free of asbestos.
  - V. Contractor's personnel shall not be exposed to asphalt fumes in excess of the National Institute for Occupational Safety and Health (NIOSH) recommended ceiling limit of 5 milligrams of asphalt fumes per cubic meter of air ( $5 \text{ mg/m}^3$ ), in any 15-minute period. NIOSH provides recommendations for control of asphalt fumes.
  - W. Work that generates visible dust requires submission of a Dust and Debris Control Plan to prevent exposure of employees, patrons, and the community to dust including crystalline silica dust. Be prepared to submit air-monitoring data to demonstrate effectiveness of dust control measures. If dust cannot be controlled, submit Respiratory Protection Program in compliance with 29 CFR §1926.103 or 29 CFR §1910.134, and submit evidence of air monitoring, training documentation, medical clearance for respirator use, and respirator fit tests for tight-fitting respirators.
  - X. Ensure that the level of exhaust emissions from equipment such as air compressors and generators, are within acceptable limits to comply with clean air regulations and that workers are



- not exposed to exhaust fumes or gases (carbon monoxide, sulfur dioxide, nitrogen oxides, hydrogen sulfide, aldehydes) in excess of the most stringent of occupational exposure limits.
- Y. For all work generating waste water, submit a Waste Water Discharge Plan that describes how the Contractor will treat and release wastewater generated by activities at the work Site, for all work that generates wastewater. Apply for Temporary Discharge Permit from local sewer authority, as required by specific site activities. Comply with Consolidated Plan prepared by Authority for Bus Divisions and Rail Yards.
  - Z. For Abrasive Blasting activities, all MSDSs for abrasives shall be submitted for Approval prior to abrasive blasting activities. Only abrasives containing less than 1 percent crystalline silica shall be used for abrasive blasting.
  - AA. For Hot Work activities, provide documentation on certification for personnel who perform welding on Authority property. Ventilation in accordance with OSHA regulations shall be provided for hot work such as welding, cutting, or brazing.
  - BB. At the Site of the work, a First Aid Kit shall be provided and fully equipped to meet the needs of the anticipated work force. Employees expected to render First Aid or CPR shall have the proper current certifications and be trained in Bloodborne Pathogens in accordance with 29 CFR §1910.1030.
  - CC. Work shall not be performed in any area in use by the public, unless specifically required by the Contract or directed in writing by the Contracting Officer Representative. Give at least 48 hours notice to the Contracting Officer Representative before beginning such work.
  - DD. In cases where the movement of Contractor's motorized equipment is necessary, flag persons shall be provided to warn and direct personnel and patrons away from the area of travel. Flag persons shall be certified as trained in proper flagging techniques and Contractor employees involved in traffic control and devices shall be certified as trained in traffic management as required by the State or local jurisdiction. Certification shall be documented.
  - EE. When it is necessary to maintain use of work areas involving stations, sidewalks, elevators, platforms, bus shelters, vehicular roadways, building entrances, and corridors, protect the area with guardrails, substantial barricades, temporary fences, overhead protection, and temporary partitions as deemed necessary by the Contracting Officer Representative. Under no circumstances will yellow or orange tape strung between barricades, or the like, be acceptable as a substantial barricade. Open manholes, access openings, or other breaks in the normal walking surface shall be isolated from personnel and the public using barricades.
  - FF. Sidewalks, entrances, platforms, mezzanines, or any other location where personnel or the public traverses, shall always be kept clear of obstruction, tools, ladders, work debris, and excavation materials. When necessary, temporary sidewalks or pathways shall be provided for pedestrian traffic. Temporary sidewalks or pathways shall be free of tripping hazards and protected by proper guardrails and barricades. Temporary means of egress and access shall be marked for easy recognition. If work is required above sidewalks, overhead protection shall be provided. Protected walkways shall be Approved by the Authority.
  - GG. Appropriate warning signs and instructional safety signs shall be conspicuously posted in all areas involving construction activities. Work involving electrical systems or equipment in or near the area to which personnel or the public have access shall be isolated using barricades and partitions. Exposed, live circuits shall not be left accessible to personnel or the public or left dangling overhead. Before completion of the Work:
    - 1. Ensure that all wiring is insulated and properly positioned.
    - 2. Verify grounding, bonding, or both, of all metallic conduit, wiring or electrical equipment that is in the areas of contractual effort, and to which the public can make contact.

3. Notify the Contracting Officer Representative immediately in those instances where verification cannot be made.
4. Contractor's personnel working near the platform edge or in the right-of-way shall wear reflective safety vests with the tear-away feature, to identify them to passing trains, as directed by the Authority at the right-of-way safety training required in this Section. The safety vests shall comply with the ANSI/ISEA 107 guideline entitled American National Standard for High-Visibility Safety Apparel. All of the Contractor's personnel are required to attend safety training provided by the Authority before starting work near the platform edge or in the right-of-way.

HH. Use of Cranes and Derricks:

1. General Safety Requirements. Comply with the following:
    - a. 29 CFR §1910.180 through §1910.189.
    - b. 29 CFR §1926.550 through §1926.556
    - c. U.S. Army Corps of Engineers, Safety Manual EM-385-1-1.
  2. No part of any crane or derrick boom shall swing over Authority patrons, tracks, or stations without an Authority Approved shield or procedure.
  3. Placement of crane or derrick shall be coordinated with the Contracting Officer Representative.
  4. A supervisory or a red tag power outage is required. Exceptions may be granted on an individual basis after a review and approval by the Authority.
  5. Hardhat requirements are enforced.
  6. "Swing Stop" requirements may be instituted based on the hazards involved.
  7. Use of cranes and derricks over common corridor railroads and highways is under the rules of the affected common corridor railroad or highway owner.
  8. All cranes used for erecting components of precast concrete on the Project shall be equipped with Load Moment Indicating (LMI) devices or Rated Capacity Indicators (RCI), an anti-two-block device. All crane operators shall be certified to operate the type of crane used by the National Commission for the Certification of Crane Operators (CCO) and their CCO certificates shall be submitted to the Contracting Officer Representative. To increase the factor of safety when picking structural elements of the building, all cranes shall have load capacity charts reduced (de-rated) by a factor of 30 percent. Submit a lift plan showing all pertinent information demonstrating that the total load does not exceed 70 percent of the maximum before crane delivery to the Project Site.
- II. All jobsite visits for visitors and tours shall be coordinated through Contracting Officer Representative in accordance with the WMATA Construction Safety and Environmental Manual, and Contractor insurance requirements.

1.6 ENVIRONMENTAL SAFETY REQUIREMENTS

- A. Comply with the most stringent of federal, state, or local environmental regulations for air, water, land, and waste in order to maintain the safety and health of employees, Authority patrons, and the community.
- B. If task requires specialized licenses or certifications, for example "lead or asbestos abatement contractor's license or certified tank installer/remover", show evidence of such registration prior to

- commencement of work. If the Work requires specialized training, for example lead or asbestos training, show evidence that employees have received such training prior to commencement of work.
- C. If the Work requires transportation of hazardous materials or hazardous substances, provide evidence of Department of Transportation General Awareness Driver's Training in compliance with 49 CFR §172 and Commercial Driver's License in compliance with 49 CFR §390-397, prior to commencement of work.
  - D. All hazardous materials and hazardous substances shall be stored in "Performance Oriented Packaging" in compliance with 49 CFR §178, Subpart L.
  - E. If the Work requires disposal of hazardous wastes, disposal shall be to a Treatment/Storage/Disposal facility with a Part B Permit and the waste hauler shall have a state or local license and U.S. EPA identification number. Apply and pay for temporary EPA Generator ID number required to dispose of hazardous waste. Submit evidence of all applicable licenses and permits along with the name and address of the waste disposal facility where hazardous waste materials are to be disposed, prior to commencement of work.
  - F. If the Work involves response to spills of hazardous materials, hazardous substances or hazardous wastes, all personnel shall have appropriate training that complies with 29 CFR §1910.120.

PART 2 – PRODUCTS (not used)

PART 3 – EXECUTION (not used)

END OF SECTION



**SECTION 01115**  
**SAFETY AND SECURITY CERTIFICATION**

**PART 1 – GENERAL**

**1.1 SUMMARY**

- A. This Section includes the process used to certify that the WMATA system complies with the specified safety and security requirements.

**1.2 REFERENCES**

- A. Federal Transit Administration
  - 1. Handbook of Transit Safety and Security Certification
  - 2. Guideline 5800.1 - Safety and Security Management Guide for Major Capital Projects
- B. Transportation Safety Institute
- C. WMATA Safety and Security Certification Program Plan

**1.3 JOB CONDITIONS**

- A. A Sample Certifiable Items List (CIL) is provided as an attachment to Book 2. It serves as an example of the CIL that shall be completed by the Contractor for each task throughout the Period of Performance of this Contract. The design related entries in the CIL will be completed by the Authority and will be provided to the Contractor with each task.

**1.4 SUBMITTALS**

- A. Submit the following documents for approval in accordance with Section 01330, SUBMITTAL PROCEDURES:
  - 1. Safety and Security Certification Plan (SSCP) within 60 Days of NTP.
  - 2. Updated CIL for construction and testing every 60 Days for the duration of each assigned task.
  - 3. If design changes are proposed by the Contractor, updated CIL submitted with each Contractor proposed design change.
  - 4. Final CIL for construction and testing and Certification Report in accordance with FTA Guideline 5800.1, Safety and Security Management Guidance for Major Capital Projects.
  - 5. If design changes are proposed by Contractor, updated Hazard and Vulnerability Resolution and Tracking System submitted with each Contractor proposed design change.
  - 6. If design changes are proposed by Contractor, Preliminary Hazard Analysis and Threat Vulnerability Assessment submitted with each Contractor proposed design change.

1.5 QUALITY

- A. Contractor's Certification Program Representative shall have, within the last 3 years, completed a recognized certification training course provided by Federal Transportation Administration (FTA), Transportation Safety Institute (TSI), or other recognized Safety and Security Certification Training Agency.

1.6 GENERAL

- A. The purpose of the Safety and Security Certification program is to ensure that:
1. The design, construction, fabrication, installation, testing, and commissioning of all safety critical facility and system elements have been evaluated for compliance with the safety and security requirements, including applicable codes and standards, and to verify their readiness for operational use.
  2. WMATA's rail and bus facilities and systems are operationally safe and secure for customers, employees, and the public.
- B. The objective is to achieve an acceptable level of safety and security risk through a systematic approach to safety hazard and security vulnerability management through adherence with the design criteria, compliance with technical specifications, and testing verification.

1.7 SECURITY AND SAFETY CERTIFICATION PROCESS

- A. Participate in the WMATA Safety and Security Certification Program Plan for the duration of the Contract as follows:
1. Contractor's Certification Program Representative shall manage and oversee compliance with the WMATA Safety and Security Certification Program Plan requirements.
  2. Participate in working groups with Authority Safety, Security, and Project Staff to maintain the CIL and the certification status of the items on the Certifiable Items List.
  3. Authority will identify certifiable items and Contractor shall complete development of the Authority provided sample CIL to address all Contract specific items requiring safety and security certification based on the Contractor's construction and testing plan, and input from the working group
  4. Identify the safety and security criteria, technical specifications, and testing requirements, including applicable codes and standards, for each certifiable item on the CIL for each certifiable item on the CIL that resulted from a Contractor proposed design change.
  5. Demonstrate that the design complies with the identified safety and security requirements for those items on the CIL that resulted from a Contractor proposed design change.
  6. Demonstrate that the construction, fabrication, and installation comply with the safety and security requirements for those items on the CIL.
  7. Demonstrate through testing the compliance with the safety and security requirements for those items on the CIL.
  8. If changes are proposed to the design, identify and categorize project hazards by their potential severity and probability of occurrence. Analyze each hazard for its potential impact to the Project.
  9. If changes are proposed to the design, evaluate the project for susceptibility to potential threats and identify design corrective actions that can reduce or mitigate the risk of serious consequences from a security incident. Analyze each identified threat for its potential impact to the project.

10. Provide and update a tracking system for all hazards and threat vulnerabilities identified as a result of Contractor proposed design changes.
11. Maintain a document management system within the Authority's Project Management Software System (PMSS) that enables the retrieval of verification documentation that demonstrates compliance with the safety and security requirements in construction, fabrication, installation, and testing for each item in the CIL. Verification documentation may consist of drawings, reports, fabrication approvals, inspection, test results, certificates, or other supporting documents.
12. Complete the construction/installation, and testing sections of the CIL as compliance is achieved and provide the required CIL verification documentation to WMATA as the construction and testing progresses.
13. Prepare construction and testing component of the Certification Report and include design component if design changes were proposed by the Contractor and Approved by the Authority.

PART 2 – PRODUCTS (Not Used)

PART 3 – EXECUTION

3.1 CERTIFICATION PROGRAM REPRESENTATIVE

- A. Appoint a Certification Program Representative with the qualifications noted in this Section to lead and coordinate the certification process.

3.2 SAFETY AND CERTIFICATION PROGRAM WORKSHOPS

- A. Conduct Safety and Security workshops on a monthly basis for the duration of the Contract.

3.3 CIL AND FINAL REPORT

- A. Prepare, update and complete CIL throughout the Period of Performance of the Contract and prepare final CIL and Certification Report prior to Acceptance of the Project.

END OF SECTION





## SECTION 01116

### IDENTIFICATION AND SECURITY

#### PART 1 – GENERAL

##### 1.1 SUMMARY

- A. This Section includes identification and security requirements for work on Authority Property.

##### 1.2 DEFINITIONS

- A. Authority Property: Includes the Authority's Rail and Bus Operating System and Authority administrative facilities, whether under construction or being rehabilitated.

##### 1.3 SUBMITTALS

- A. Forms necessary to initiate background check process, including color copy of the front and back of Contractor personnel's Driver License or other accepted form of identification.

##### 1.4 PRE-EMPLOYMENT CRIMINAL BACKGROUND CHECK

- A. Criminal background checks of all Contractor employees working at a WMATA facility on this Contract will be required pursuant to Metro Policy/Instruction 7.40/0, Background Screenings and Metro Policy/Instruction 6.10/5, Metro Employee Identification Cards, Section 5.04. Eligibility for access to WMATA property will be based on WMATA's pre-employment Criminal Background Check criteria. WMATA will provide the Contractor employees with background check consent forms that the Contractor's employees must complete and sign. The forms will require the Contractor employees to appear in person, provide their full legal names, including middle initials if applicable, as well as their Social Security numbers, in addition to other information that will be necessary to conduct the background checks. The operating hours are Monday through Friday from 0700 to 1530 except holidays. Upon receipt of the completed, signed forms, WMATA will conduct background checks including criminal court searches and Social Security Number verifications of the Contractor employees. If there is derogatory information that would disqualify a Contractor employee from receiving a badge to access WMATA property, the Contractor and its employee will be notified that the background check failed. The completed forms are secured in a locked file cabinet and are destroyed 1 year after the expiration date on the Contractor employee's badge. These background checks are expected to take 1 business day for processing. The Contractor employee must allow sufficient time for completion. The background check is free of charge.
- B. Background checks are conducted to promote a safe work environment and to protect our company's most important assets: the people we serve and the people with whom we serve. This enables WMATA management to make prudent decisions and maintain a high quality workforce. Contractor employees who successfully complete the background checks are eligible to enter WMATA property once they are issued a Contractor badge. Contractor employees who do not authorize background checks or whose background checks are unsatisfactory will not be granted Contractor badges or access to WMATA property. The records generated by these background checks that contain private information will not be disclosed unless disclosure is required under the PARP/Privacy Policies.

##### 1.5 IDENTIFICATION AND SECURITY CHECKS

- A. All employees of the Contractor and its Subcontractors working on WMATA projects shall prominently display an identification badge issued by the Authority.

- B. Contractor Photo ID Badges: Individuals requiring the Contractor photo ID badges are subject to the following identification and security checks
  - 1. Provide valid and current photo identification, such as a State-issued Driver's License, State-issued Identification Card, U.S. Passport, or identification from the Immigration and Naturalization Service, such as a Permit to Work or a Permanent Residence Card (Green Card).
  - 2. The individual's identification may be matched against the FBI Watch List and security clearance.
  - 3. The photo identification will be matched against the Contractor's list of employees authorized to work on a particular job.

1.6 NON-CONFORMANCE

- A. In the event any employee of the Contractor or its Subcontractors fails to adhere to the requirements of this Section, the employee or Subcontractor will be removed from the job until non-conformance is corrected. Such removal will not be grounds for any time extension or additional compensation.

1.7 ADMINISTRATION

A. Contractor Photo ID Badge:

- 1. A Contractor Photo ID badge will be required if the individual will be present on Authority Property. Issuance of the Contractor Photo ID badge will require the individual to schedule and report to the Authority's Jackson Graham Building at 600 Fifth Street, NW, Washington DC for processing.
- 2. Contractor Photo ID badge takes approximately 14 Days to obtain unless personnel have lived outside of the United States within the last year, in which case the background checking process will require additional time to complete.
- 3. It will be the Contractor's responsibility to immediately notify the Contracting Officer Representative if a worker loses his or her Contractor Photo ID badge. A fee of \$25 will be charged for each lost badge.
- 4. All Contractor Photo ID badges shall be returned to the Contracting Officer Representative when they are no longer needed.
- 5. Contractor Photo ID badges shall be renewed on an annual basis.

PART 2 – PRODUCTS (not used)

PART 3 – EXECUTION (not used)

END OF SECTION

**SECTION 01141**  
**ACCESS TO SITE**

**PART 1 – GENERAL**

**1.1 SUMMARY**

- A. This Section specifies requirements for gaining access to Site and describes work hours the Contractor will be allowed in WMATA Trackway and Operating Facilities.

**1.2 DEFINITIONS:**

- A. Non-Revenue Hours of Work – When the Authority is not operating revenue service trains and the track is made available to the Contractor.
- B. Revenue Service Adjustment (RSA) Hours of Work – There are two service conditions:
  - 1. Single tracking when a single track is made available to the Contractor to work while the Authority operates trains in both directions on the opposite track.
  - 2. Shutdowns when both tracks of a section of line are made available to the Contractor to work.

**1.3 REFERENCES**

- A. Contract Documents - WMATA Safety and Security Plans and Documents

**1.4 IDENTIFICATION CARDS**

- A. All Contractor personnel needing access to trackway or WMATA operating facilities must have WMATA Safety Certification badges. Badges shall be displayed in a prominent manner on each person while engaged in the Work. Access to the Site will be granted only to properly accredited representatives of the Contractor and its Subcontractors when they have completed the required WMATA safety certification and training and Safety Certification Badges.

**1.5 HOURS OF WORK**

- A. Work such hours per shift, with or without overtime, as many shifts per day and as many days per week as necessary to complete the various parts of the Work and the entire Work within the dates specified and within the restrictions listed below.
- B. Coordinate and schedule all work with the Contracting Officer Representative to ensure that the Contractor's activities do not interfere with the operation of or access to the Authority's facilities.
- C. Hours for Work will be provided in Section 01110, SUMMARY OF WORK for each task.
- D. The number of hours of Authority escort support that will be supplied for each task and for each access category will be provided in Section 01110, SUMMARY OF WORK for each task.
- E. Access types when access to facilities for personnel, material and equipment is via the safety walk or trackway are described below:
  - 1. Personnel Access: "Platform", "Train Drop", "Track" and "Track Walk" access. The Hours of Work include the travel time between the nearest Metro Rail Station and the facility location as indicated.
    - a. "Platform": Personnel shall access the facility on foot via the safety walk from the nearest Metro Rail Station under the supervision of an Authority escort in accordance with

- SOP #49 if safety fencing or temporary safety fencing is in place or in accordance with SOP #19 if it is not.
- b. "Train Drop": Personnel will be dropped off at facility and picked up from facility by non-rush hour Metro Rail trains under the supervision of an Authority escort in accordance with SOP #19. Personnel will be picked up and dropped off from the nearest Metro Rail Station.
  - c. "Track" and "Track Walk": Personnel shall access the facility on foot via the safety walk from the nearest Metro Rail Station under the supervision of an Authority escort in accordance with SOP #19.
2. Material and Equipment Access from "Track": At locations where the only access to a facility is via the track way, a prime mover, standard flat car, and operator will be provided by WMATA during non-revenue or RSA hours for removal of material and equipment and delivery of material and equipment. This service shall be coordinated through the Contracting Officer Representative and will be provided no more than one time per facility location for removal of materials and equipment and one time per facility location to deliver materials and equipment, all under the supervision of an Authority escort in accordance with SOP #28. If the sequence of work permits, Contractor shall schedule this service to supply multiple facility locations in the same trip. Materials and equipment will be picked up and dropped off from Metro Rail Yards as follows (routes are identified in the Contract Drawings):
- a. Facility locations on "A" route – Shady Grove Yard
  - b. Facility locations on "B" route – Glenmont/Brentwood Yards
  - c. Facility locations on "C" route – Alexandria Yard
  - d. Facility locations on "D" route – New Carrollton Yard
  - e. Facility locations on "E" route – Greenbelt Yard
  - f. Facility locations on "F" route – Greenbelt/Branch Avenue Yards
  - g. Facility locations on "G" route – Branch Avenue Yard
  - h. Facility locations on "J" route – Alexandria Yard
  - i. Facility locations on "K" route – West Falls Church Yard
  - j. Facility locations on "N" route – West Falls Church Yard
- F. Typical working Hours for Work not requiring access to the trackway may be selected by the Contractor and coordinated through the Contract Officer Representative, for facility locations accessible from local streets or ventilation and fan shafts. Minimum shift length per day shall be defined in Section 01110, SUMMARY OF WORK for each Task. Personnel and material access requirements are described below:
1. Personnel Access:
    - a. "Access Road" or "Grade Level": Personnel shall access the facility from the facility access road under the supervision of an Authority escort in accordance with SOP #49.
    - b. "Fan Shaft" or "Vent Shaft": Personnel shall access the facility via fan shaft or vent shaft stairs under the supervision of an Authority escort in accordance with SOP #49.

2. Material and Equipment Access from "Access Road" or "Grade Level" or "Hatch": Remove or deliver material and equipment under the supervision of an Authority escort in accordance with SOP #49.
- G. Project Schedule, as required in Section 01322, CONTRACT PROGRESS REPORTING, shall include a detailed construction-phasing plan based on the Hours of Work commitments by the Authority. If the phasing plan requires RSA hours, these shall be identified by the Contractor in the Project Schedule.
- H. There are Federal Holidays that occur on Monday's throughout the year creating a 3-day weekend. In addition to the Hours of Work indicated in Article 1.05G herein, on holiday weekends listed below, single track RSAs will be permitted between 2200 Friday and 0400 Tuesday and complete shutdown RSAs will be permitted between 0300 Saturday and 0400 Tuesday. Availability of these Hours of Work is limited and their use, if available, must be coordinated through the Contracting Officer Representative.
1. Martin Luther King Day
  2. President's Day
  3. Memorial Day
  4. Columbus Day
  5. Labor Day
- I. The Hours of Work associated with non-revenue and RSAs are noted below. All planned access to trackway shall be incorporated into the Project Schedule by the Contractor.
1. Weeknight Non-revenue (0130 to 0400) – These hours can be made available for short duration activities that cannot be interrupted by train service.
  2. Weeknight early out single tracking (1200 to 0400 or as defined in Section 01110, SUMMARY OF WORK for each Task) – These hours can be made available for material and equipment removal and delivery. Coordinate individual RSA's at each facility location with the Contracting Officer Representative.
- J. When Contractor requests RSAs, and they are granted by the Authority, Contractor shall staff each available Shift for the duration of the RSA. Failure to do so shall require Contractor to reimburse the Authority for the cost of Authority support staff for each Shift that Contractor did not staff.
- K. RSAs will not be permitted during the following periods in any calendar year:
1. March 12 through April 21
  2. The first Saturday of June (Race for the Cure)
  3. The week containing July 4 including the preceding and succeeding weekends.
  4. The 4<sup>th</sup> Sunday of October (Marine Corps Marathon)
  5. Thanksgiving eve through the following Monday
  6. Christmas eve and Christmas day
  7. New Year's eve and New Year's day

- L. Many times during a calendar year there are large events scheduled in the Washington DC area that require special attention by WMATA. These events are typically scheduled no sooner than 90 Days in advance of their occurrence. Plan no more than three such events in any calendar year. WMATA will notify the Contractor of the scheduling of these events as soon as they become known. If the event conflicts with a scheduled RSA, then the Contractor RSAs will need to be advanced or delayed 1 week unless there is conflict with the black-out periods listed above.
- M. There shall be no RSAs starting prior to 0130 on nights of regularly scheduled sporting events such as baseball, basketball, hockey, or soccer.
- N. Emergencies, excluding Acts of God, arise during the course of Metrorail operations that could cause the cancellation of a scheduled RSA. Anticipate no more than four cancellations within a calendar year. If an emergency occurs, then the Contractor RSAs will need to be delayed to the next available date.

PART 2 – PRODUCTS (not used)

PART 3 – EXECUTION (not used)

END OF SECTION

## SECTION 01250

### CONTRACT MODIFICATION PROCEDURES

#### PART 1 – GENERAL

##### 1.1 SUMMARY

- A. This Section specifies procedures for making Contract Modifications.

##### 1.2 GENERAL

- A. Out-of-Scope Items. Specific approval must be received from the Contracting Officer Representative prior to doing work, which may be considered to be outside the Scope of Work and for which additional reimbursement may be requested in accordance with the General Conditions.
- B. Requests for additional work may be initiated by the Authority. Claims for an increase in Contract Price shall be thoroughly documented as specified in the General Conditions and directed to the Contracting Officer Representative who, upon Approval, will issue a Modification stating the amount of the increase in fee.
- C. Should the Contractor be excused from the provision of certain services identified in this Scope of Work, the Contractor will be requested to give a credit to the Authority. The offer for the credit shall be documented and directed to the Contracting Officer Representative who, upon Approval at the appropriate level, will issue a Modification.

##### 1.3 TIME AND MATERIALS WORK FOR THE CONSTRUCTION EFFORT

- A. In the event equitable adjustment cannot be agreed to in a timely manner, the Authority reserves the right to order work on a time and materials basis as specified in the General Conditions. When work is ordered under this Section, notwithstanding the provisions of other Sections, compensation for the Work shall be determined as hereinafter provided and shall constitute the total compensation to be paid for the changes to the Work. The methods, labor, materials, and equipment used in the performance of such work shall be subject to the Approval of the Authority.
- B. Work performed by or for the Contractor: labor, materials, services, and equipment shall be furnished by the Contractor or by a Subcontractor or by others on behalf of the Contractor. The Contractor will be paid therefor as hereinafter provided, except where agreement has been reached to pay in accordance with Article 1.03C. below.
  - 1. Labor: The cost of labor used in performing the work, whether the employer is the Contractor, Subcontractor, or other forces, will be the sum of the following:
    - a. The gross actual wages paid including income tax withholding but not including any employer payments to or on behalf of workmen for health and welfare, pension, vacation, insurance, and similar purposes.
    - b. To the actual gross wages, as defined in Article 1.03B.1.a above, will be applied a percentage based upon current applicable labor rates concerning payments made to or on behalf of workmen other than actual wages, which percentage shall constitute full compensation for all payments other than actual gross wages as defined in Article 1.03B.1.a above and subsistence and travel allowance as specified in Article 1.03B.1.c below. The Contractor shall compute a separate percentage for each craft or a composite percentage for all crafts, if so approved by the Authority. All computed percentages shall be submitted to the Contracting Officer Representative for Approval within 30 Days after start of construction work or as directed by the Contracting Officer Representative prior to time and materials work being performed.

- c. Subsistence and travel allowance paid to such workmen if required by collective bargaining agreements. The charges for labor shall include all classifications through foremen when engaged in the actual and direct performance of the Work. They shall not include charges for such overhead personnel as assistant superintendents, superintendents, office personnel, timekeepers, and maintenance mechanics.
  2. Materials: The cost of materials required for the accomplishment of the Work will be delivered cost to the purchaser, whether Contractor, Subcontractor, or other forces, from the Supplier thereof, except as the following are applicable:
    - a. If a cash or trade discount by the actual supplier is offered or available to the purchaser, it shall be credited to the Authority notwithstanding the fact that such discount may not have been taken.
    - b. If materials are procured by the purchaser by any method, which is not a direct purchase from and a direct billing by the actual supplier to such purchaser, the cost of such materials, including handling, shall be deemed to be the price to the actual Supplier as determined by the Contracting Officer Representative.
    - c. If the materials are obtained from a supply or source owned wholly or in part by the purchaser, payment therefor will not exceed the price paid by the purchaser for similar materials furnished from said source on Contract items or the current wholesale price for such materials delivered to the job Site, whichever price is lower.
    - d. The cost of such materials shall not exceed the lowest current wholesale price at which such materials are available in the quantities concerned, delivered to the job Site, less any discount as provided in Article 1.03B.2.a above.
    - e. If the Contractor does not furnish satisfactory evidence of the cost of such materials from the actual supplier thereof, the cost shall then be determined in accordance with Article 1.03B.2.d above.
    - f. The Contractor will not be compensated for indirect costs and profit on Authority-furnished materials.
  3. Equipment: The Contractor will be paid for the use of equipment in accordance with the Contract. The Contractor shall furnish all data, which might assist the Authority in the establishment of such rates.
    - a. Operators of equipment will be paid under Article 1.03B.1 above.
    - b. Small tools (defined as equipment less than \$2,000 in acquisition costs) are computed at a maximum of 5 percent of direct base labor wages.
  4. Subcontracts: The cost for Subcontract work at any tier will be the actual cost to the Contractor/Subcontractor for work performed by a Subcontractor as computed in accordance with Articles 1.03B.1 through 1.03B.3 above. For the purposes of this Article, Subcontractor is defined as an individual, partnership, corporation, association, joint venture, or any combination thereof, who contracts with the Contractor to perform work or labor or render service on or about the work. The term Subcontractor shall not include those who supply materials only. When work paid for on a time and materials basis is performed by forces other than the Contractor's organization, the Contractor shall reach agreement with such other forces as to the distribution of the payment made by the Authority for such work, and no additional payment therefore will be made by the Authority by reason of performance of the Work by a Subcontractor or by others.



5. To the totals, completed as indicated in Articles 1.03B.1 through 1.03B.4, shall be added field office overhead as follows:
    - a. If the costs determined above do not exceed \$100,000 and the adjustment in time for Contract performance is 10 Days or less, the markup shall be computed in accordance with Article 1.04 below.
    - b. In all other cases, the most recent audited daily field office overhead rate will be used.
  6. Home Office General and Administrative (G&A) costs will be determined using the most recent audited rate at the time the work was accomplished. A fixed rate of 3 percent will be used in the absence of an audited rate.
  7. Profit will be negotiated as provided in Article 1.07 below.
  8. A percentage for Contractor's bond, not to exceed 1 percent, may be added.
- C. Special items of work: If the Contracting Officer Representative and the Contractor, by agreement, determine that either: an item of time and materials work does not represent a significant portion of the total Contract Price, or such item of work cannot be performed by the forces of the Contractor or the forces of any of its Subcontractors, or it is not in accordance with the established practice of the industry involved to keep the records, which the procedure outlined in Article 1.03B above would require, charges for such special time and materials work item may be made on the basis of invoices for such work without complete itemization of labor, materials, and equipment rental costs. To such invoiced price, less a credit to the Authority for any cash or trade discount offered or available, whether or not such discount may have been taken, will be added a negotiated amount not to exceed 5 percent of the discounted price, in lieu of the negotiated lump sum not to exceed the percentages provided for in Article 1.03B above.
- D. Records: The Contractor shall maintain its separate records in such a manner as to provide a clear distinction between the direct costs of work paid for on a time and materials basis and the cost of other operations.
1. The Contractor shall prepare, and furnish to the Contracting Officer Representative one electronic copy of report sheets of each day's work paid for on a time and materials basis the day after such work was performed. The daily report sheet shall itemize the materials used, and shall cover the direct cost of labor and the charges for equipment rental, whether furnished by the Contractor, Subcontractor, or other forces, except for charges described in Article 1.03C above. The daily report sheet shall provide names or identifications and classifications of workmen, the hours worked, and the size, type, and identification number of equipment, and hours operated.
  2. Material charges shall be substantiated by valid copies of vendor's invoices. Such invoices shall be submitted with the daily report sheets, or if not available, they shall be submitted with subsequent daily report sheets. Should said vendor's invoices not be submitted within 60 Days after the date of delivery of the material or 15 Days after acceptance of the Work, whichever comes first, the Authority reserves the right to establish the cost of such materials at the lowest current wholesale prices at which such materials are available in the quantities concerned delivered to the location of the Work less any discounts provided in Article 1.03B.2.a above.
  3. Said daily report sheets shall be signed by the Contractor or its authorized agent.
  4. The Contracting Officer Representative will compare the Authority's records with the Contractor's daily report sheets, make any necessary adjustment, and compile the costs of work paid for on a time and materials basis on daily time and materials work report forms furnished by the Authority. When these daily reports are agreed upon and signed by both parties, they shall become the basis of payment for the work performed, but shall not preclude subsequent adjustment based on a later audit. The use of any specific Authority form, such as

the Daily Report – Labor, Materials, & Equipment Form C-113, to segregate change order costs does not, in and of itself, invoke the provisions of this Article 1.03 or other provision of this Contract.

- E. Payment: Payment as provided in Articles 1.03B and 1.03C above shall constitute full compensation to the Contractor for performance of work paid for on a time and materials basis and no additional compensation will be allowed therefore.

#### 1.4 EQUITABLE ADJUSTMENT FOR MINOR CONTRACT MODIFICATIONS FOR THE CONSTRUCTION EFFORT

- A. When the Authority and Contractor agree to an additive or deductive amount for a Modification to this Contract made pursuant to this Contract when the fair and reasonable price in aggregate amount does not exceed \$100,000, and further agree to an adjustment in the time for Period of Performance resulting from said Modification, which increases or decreases the completion date 10 or less Days, the equitable adjustment in Contract amount shall consist of the sum of the following:

1. Direct labor, material, and equipment costs as agreed to by the Authority and Contractor (small tools, defined as equipment less than \$2,000 in acquisition costs, are included in equipment costs and computed at a maximum of 5 percent of direct base labor wages.)
2. Job Office Overhead costs, the sum of which shall be limited to a maximum of 10 percent of direct labor costs, including fringe benefits, but excluding FICA, FUTA, and State Unemployment Insurance (SUI); a maximum of 10 percent of direct material costs; a maximum of 5 percent of direct equipment costs (including small tools); and a maximum of 5 percent of Subcontract costs.
3. Home Office General and Administrative (G&A) costs are computed using the most recent audited rate or a fixed rate of 3 percent in the absence of an audited rate.
4. Profit will be determined in accordance with the guidelines specified in Article 1.06 below.

- B. In using the above rates, the following shall apply:

1. Payroll Tax (FICA, FUTA, and SUI) amounts are added immediately after direct and indirect costs are totaled.
2. Subcontractors' indirect costs and profit shall be computed in the same manner as above.
3. Indirect costs shall not be duplicated in direct costs.
4. When the Period of Performance is increased, the change in Contract amount for direct and indirect costs computed by application of the above rates includes costs of impact and extended performance due to the time extension and no further consideration of costs arising from the specific Modification and cited pending change orders (PCOs) will be given. The Contractor will not receive both a percentage and a daily rate markup for job office overhead costs when a time extension to the Period of Performance is recognized.
5. Bond costs will be allowed at actual cost without markup.

- C. Equipment rates shall be determined from prior Authority audits. In the absence of audited rates for equipment owned or controlled by the Contractor, hourly rates shall be computed in the same fashion as described in Article 1.07D.

#### 1.5 COST OR PRICING DATA

- A. The Contractor shall submit to the Contracting Officer Representative, either actually or by specific identification in writing an electronic copy of cost or pricing data under the conditions described in

- this Paragraph and certify that, to the best of the Contractor's knowledge and belief, the cost or pricing data submitted is accurate, complete, and current as of the date of execution, which date shall be as close as possible to the date of agreement on the negotiated price of the Contract Modification. The cost or pricing data shall be submitted at the time the Contractor submits its proposal for the pricing of any Modification to this Contract, whether or not cost or pricing data was required in connection with the initial pricing of the Contract, when the Modification involves aggregate increases or decreases in costs plus applicable profits expected to exceed \$100,000, or less at the discretion of the Authority Representative.
- B. The submittal of certified cost or pricing data will not be required if the price is based on adequate price competition, established catalog or market prices of commercial items sold in substantial quantities to the general public, or prices set by law or regulation. The Contractor agrees that the terms "adequate price competition" and "established catalog or market prices of commercial items sold in substantial quantities to the general public" will be determined by the Authority in accordance with the guidelines as set forth in Subpart 15.8 of the Federal Acquisition Regulations (48 CFR 15.8).
- C. Cost or pricing data consists of all facts existing up to the time of agreement on price, which prudent buyers and sellers would reasonably expect to have a significant effect on the price negotiations for the Modification. The definition of cost or pricing data embraces more than historical accounting data; it also includes, where applicable, such factors as Subcontractor, Supplier, and vendor quotations, nonrecurring costs, changes in construction methods, unit cost trends such as those associated with labor efficiency and any management decisions which could reasonably be expected to have a significant bearing on costs under the proposed Modification and the Contract Work. Cost or pricing data consists of all facts, which can reasonably be expected to contribute to sound estimates of future costs as well as to the validity of costs already incurred. Cost or pricing data, being factual, is that type of information, which can be verified. Because the certificate pertains to cost or pricing data, it does not make representations as to the accuracy of the Contractor's judgment on the estimated portion of future costs or projections. The certificate does, however, apply to the data upon which the Contractor's judgment is based.
- 1.6 CONTRACT MODIFICATIONS, REQUIREMENTS FOR PROPOSALS, PRICE BREAKDOWN, NEGOTIATION OF PROFIT
- A. The Contractor, in connection with any proposal it makes for a Contract Modification as specified in Section 00750, ACCOUNTING AND RECORD KEEPING, shall furnish a price breakdown, itemized as required by the Contracting Officer Representative. Unless otherwise directed, the breakdown shall be in sufficient detail to permit an analysis of all material, labor, equipment, Subcontract, and overhead costs, as well as profit, and shall cover all work involved in the Modification, whether such work was deleted, added, or changed. Any amount claimed for Subcontracts shall be supported by a similar price breakdown. In addition, if the proposal includes a time extension, a justification therefore shall also be furnished. The original and one electronic copy of the proposal, together with the price breakdown and time extension justification, shall be furnished by the date specified by the Contracting Officer Representative.

B. Where profit is negotiated as an element of price, with either the Contractor or Subcontractor, a reasonable profit will be negotiated for each Modification by using the following procedure as a guide:

1. Breakdown:

<b>Factor</b>	<b>Rate</b>	<b>Weight</b>	<b>Value</b>
Degree of risk	20		
Relative difficulty of work	15		
Size of job	15		
Period of performance	15		
Contractor's investment	5		
Assistance by Authority	5		
Subcontracting	25		
<b>TOTAL</b>	<b>100%</b>		

2. Based on the circumstances of each Modification, each of the above factors shall be weighted from 0.03 to 0.12 as indicated below. The value shall be obtained by multiplying the rate by the weight. From the value column when totaled the fair and reasonable profit can be determined under the circumstances of the particular Modification.

- a. Degree of risk: Where the modified work involves no risk or the degree of risk is very small, the weighting should be 0.03. As the degree of risk increases, the weighting should be increased up to a maximum of 0.12. Lump sum items will have generally a higher weighted value than unit price items for which quantities are provided. Other things to consider: The portion of the Work to be done by Subcontractors, nature of work, where work is to be performed, reasonableness of negotiated costs, amount of labor included in costs, and whether the negotiation is before or after performance of work.
- b. Relative difficulty of work: If the modified work is most difficult and complex, the weighting should be 0.12 and should be proportionately reduced to 0.03 on the simplest of jobs. This factor is tied in to some extent with the degree of risk. Things to consider: The nature of the Work, by whom it is to be done, the location, and the time schedule.
- c. Size of job: All modified work not in excess of \$100,000 shall be weighted at 0.12. Work estimated between \$100,000 and \$5,000,000 shall be proportionately weighted from 0.12 to 0.05. Work from \$5,000,000 to \$10,000,000 shall be weighted at 0.04, and work in excess of \$10,000,000 at 0.03.
- d. Period of performance: Modifications providing for an extension of time in excess of 30 Days shall be weighted at 0.12. Jobs of lesser duration shall be proportionately weighted to a minimum of 0.03 for jobs not to exceed 1 Day. No weight will be granted for this factor where there is no extension of the Period of Performance or interim dates due to work under this Modification.
- e. Contractor's investment: Should be weighted from 0.03 to 0.12 on the basis of below average, average, and above average. Things to consider: Amount of Subcontracting, mobilization payment item, Authority-furnished property, and method of making progress payments.

- f. Assistance by Authority: Should be weighted from 0.12 to 0.03 on the basis of average to above average. Things to consider: Use of Authority-owned property, equipment and facilities, and expediting assistance.
    - g. Subcontracting: Should be weighted inversely proportional to the amount of Subcontracting. Where 80 percent or more of the Work is to be Subcontracted, the weighting should be 0.03, and such weighting proportionately increased to 0.12 where all the work is performed by the Contractor's own forces.
  3. When considered necessary because of very unusual circumstances or local conditions, the range of weight may be increased to an upper limit of 0.15 if supported by adequate justification and Approved by the Authority.
  4. When negotiations between the Contracting Officer or the Contracting Officer Representative and the Contractor are joined to determine an equitable adjustment for a Modification of this Contract, the Contractor shall encourage involved Subcontractor(s) to be present and to present their cost data and to participate in the resolution of a fair and equitable adjustment. In any event, if after reasonable effort, a negotiated settlement cannot be reached between the Contracting Officer or the Contracting Officer Representative and the Contractor and the Subcontractor(s) involved, then at the request of the Subcontractor(s) concerned, the Contracting Officer or the Contracting Officer Representative may process Part 1 of a two-part Modification to cover the direct costs only, as agreed upon or, if not agreed upon, as determined unilaterally by the Contracting Officer or the Contracting Officer Representative. Subcontractor(s) requests for a Part 1 Modification shall be submitted to the Contractor, and the Contractor shall forward such requests promptly to the Contracting Officer Representative. Any payments received by the Contractor under this procedure shall be passed along within 10 Days thereafter to the Subcontractor concerned.
- C. Change orders: When the Contracting Officer directs a change in accordance with the provisions of this Contract, the Contractor shall identify in its proposal for equitable adjustment the network activities that precede and follow the change order work activities. If the change order work activities are performed concurrently with existing network activities, those concurrent network activities shall be identified. If the change order work activities restrain network activities, those restraints shall be identified.

#### 1.7 PAYMENT FOR USE OF EQUIPMENT

- A. The following methods of determination of equipment costs shall apply to all adjustments to Contract Prices arising under the provisions of the Contract except for Section 00728, TERMINATION FOR CONVENIENCE OF THE AUTHORITY, provisions thereunder.
- B. Allowable ownership and operating expense for construction plant and equipment in sound workable condition, owned by the Contractor, Joint Venture, Partnership, organizations under common control, and any equipment under lease purchase or sale-lease back agreements, will be paid for at hourly rates applicable to the Period of Performance, published in the Rental Rate Blue Book for Construction Equipment (Blue Book) by PRIMEDIA Information, Inc., by applying the following formula: the Regular Hourly Rate shall be 75 percent of the sum of the monthly rate (area adjustment map not used) divided by 176 and the estimated operating cost per hour. Regular Hourly Rate shall be full compensation for equipment ownership and operating expenses and shall include the cost of fuel, oil, lubricants, supplies, spare parts, repairs and maintenance, major overhauls, mechanics and servicing labor, depreciation, storage, insurance, interest, taxes, record keeping, and all incidentals. The cost of equipment operators is not included. For forward pricing, the Blue Book rates in effect at the time of negotiations shall apply. For retrospective pricing, the Blue Book rates in effect at the time the work was performed shall apply. Manufacturers ratings and manufacturer-approved modifications shall be used to classify equipment for the determination of the Regular Hourly Rate. The hourly rates are calculated as shown in the following example:

	<b>Regular Hourly Rate</b>	<b>Multi-shift Hourly Rate</b>	<b>Standby Hourly Rate</b>
Monthly Rental Cost	\$6,070.00	\$6,070.00	\$6,070.00
Divided by Hours	176	176	176
Hourly Rental Cost	\$34.49	\$34.49	\$34.49
Hourly Operating Cost	18.20	18.20	18.20
Subtotal	52.69	52.69	52.69
Adjustment	75%	75%	75%
Regular Hourly Rate	39.52	39.52	39.52
Status	100%	60%	40%
Payment Rate	\$39.52	\$23.71	\$15.81

1. For Contractor owned equipment as identified in Article 1.07B, the first 8 hours, or fraction thereof, usage in any one day shall be paid for at the Regular Hourly Rate, and any additional time in excess of 8 hours, shall be considered to be an additional shift, or fraction thereof, and shall be paid for at 60 percent of the Regular Hourly Rate. Standby time, if authorized by the Contracting Officer Representative, will be paid for at 40 percent of the Regular Hourly Rate. Standby time shall be limited to the regular 8-hour shift and shall not exceed 40 hours in a week. Any usage time less than 30 minutes shall be considered to be 1/2 hour.
2. For third-party rented equipment, the Authority will accept rental rates actually paid and substantiated by certified reproduced copies of invoices or bills. Such invoices or bills shall indicate the amount of operating expenses and operator wages and fringes, if any, included in the rental rate. In no case shall the bare rental rate per hour (operating expense, and operator wages and fringes not included) exceed the appropriate Regular Hourly Rate. Where required, the operating costs per hour will be agreed upon between the Contractor and the Authority using operating costs per hour from the Blue Book for the same or similar equipment
3. When approved by the Contracting Officer Representative, use of equipment not listed in the Blue Book will be permitted. An equitable hourly rate for such equipment will be established by the Contracting Officer Representative based on Contractor furnished cost data and basic information concerning the equipment. Information required to determine rates includes, but is not limited to, manufacturer, year, size, model, serial number, capacity, and weight. This information shall be furnished to the Contracting Officer Representative prior to the use of the equipment. Authority shall be granted audit access to verify information related to or pursuant to this Section.
4. The Regular Hourly Rate does not include “move-in” and “move-out” costs.
5. These equipment rates shall apply to equipment in sound workable condition. The equipment shall be of approved size and capacity to provide normal output or production required for the

work to be done. Equipment not meeting these requirements may be used only with the Contracting Officer Representative's approval and at agreed, reduced rates. Usage time or standby time will not be allowed while equipment is inoperative due to breakdown, and such equipment shall be removed from the jobsite at the direction of the Contracting Officer Representative.

- C. Items of equipment with an acquisition cost of \$2,000 or less shall be considered as small tools.
- D. Equipment costs that are paid under the equipment use rate shall not be duplicated in the Contractor's other direct or indirect costs.

PART 2 – PRODUCTS (not used)

PART 3 – EXECUTION (not used)

END OF SECTION





**SECTION 01312**  
**PROJECT MEETINGS**

**PART 1 – GENERAL**

**1.1 SUMMARY**

- A. This Section specifies administrative and procedural requirements for Project meetings.
- B. During the term of this Contract, attend meetings and conferences with officials of the Authority, governmental agencies, and others interested in the Work as may be directed by the Contracting Officer Representative. Meeting minutes, prepared by either the Contractor or the Contracting Officer Representative as specified herein, shall state the place and time of the meeting, the names and identification of those present, a brief description of the matters discussed, and the agreements reached.
- C. Meetings shall be held in the Project office or at other locations in the Washington Metropolitan Area, as needed. Contractor and other concerned parties attending these meetings shall each be represented by persons thoroughly familiar with and authorized to conclude matters relating to the Work described in the Contract Documents.

**1.2 PRE-CONSTRUCTION MEETINGS**

- A. Conduct pre-construction meetings at the Site prior to the start of construction activities that require special coordination for those activities that are deemed to require a separate meeting because of the technical nature of the installation.
- B. The Contractor's Key Staff, Subcontractors, representatives of manufacturers and fabricators involved in or affected by the installation, coordination, or integration with their materials and installations that have preceded or will follow and the Authority, the Contracting Officer Representative, and other representatives of the Authority shall attend the meeting.
- C. Notify the Authority in advance of the date, time, location, and topics for review and discussion at each pre-construction meeting. Ensure that other attendees are properly notified. Topics that may require pre-construction meetings include, but are not limited to the following:
  - 1. Installation of equipment or systems
  - 2. Items that require connection to existing Authority equipment or systems as applicable
  - 3. Other pre-installation meetings as may be called by the Contractor or the Contracting Officer Representative
- D. Agenda discussion items for the meeting may include, but are not limited to, the following:
  - 1. Safety
  - 2. QA/QC
  - 3. Temporary facilities
  - 4. Space and access limitations
  - 5. Shop Drawings, Working Drawings, Product Data, Quality Control Samples, Certifications, and Documentation
  - 6. Purchases and deliveries

7. Manufacturers' recommendations
  8. Inspection and testing requirements
  9. Required performance results
  10. Recording requirements
  11. Possible conflicts and compatibility problems
  12. Weather limitations
- E. Work shall not proceed if the meeting cannot be successfully concluded. Initiate whatever actions are necessary to resolve impediments to performance of work and schedule a follow-up meeting with the Authority at the earliest date.
- F. Record meeting minutes and distribute copies to everyone in attendance and to others affected by decisions or actions resulting therefrom.

### 1.3 PROGRESS MEETINGS

- A. Conduct progress meetings at regularly scheduled times convenient for all parties involved. Progress meetings are in addition to specific meetings held for other purposes, such as coordination and pre-construction meetings. A Three-Week Work Plan will be developed by the Contractor prior to the start of the meeting as specified in Section 01322, PROGRESS REPORTING, and will be discussed during the planning portion of the agenda. Additionally, discussions will address administrative and technical issues of concern, determining resolutions, and development of deadlines for resolution within allowable time frames.
- B. Determine, together with the Contracting Officer Representative, who should attend the meeting in addition to the Contracting Officer Representative, other representatives of the Authority, the Contractor's Key Staff, and those Subcontractors, Suppliers, or other entities critical to the current progress or involved in planning, coordination, or performance of future activities that are part of the Work.
- C. Contracting Officer Representative will publish an agenda prior to each meeting and will distribute copies to Contractor. Agenda items may include:
1. Review of minutes of the previous progress meeting
  2. Contractor's construction schedule and construction sequence
  3. Safety, including discussions of hazards and risks
  4. QA/QC, including discussion of Non-Compliance Notices
  5. Temporary facilities and services
  6. Site utilization, Site access needs and Hours of Work issues
  7. Testing and systems integration testing
  8. Updated submittals list and submittal priorities
  9. Requests for Information
  10. Documentation of information for payment requests
  11. Pending Change Orders and Modifications

12. Resource allocation
  13. Off-Site fabrication problems
  14. Purchases and deliveries
  15. Housekeeping
- D. The Contracting Officer Representative will record meeting minutes and distribute copies to everyone in attendance and to others affected by decisions or actions resulting from each meeting. Meeting minutes will document issues of significance including submittals, schedules, quality assurance/quality control, safety, problems encountered, and the assignment of responsibilities for future action.

#### 1.4 PROGRESS AND QUALITY STATUS REPORT REVIEWS

- A. A preliminary progress and quality status report meeting will be held on a monthly basis prior to the submittal of the Contractor's final Monthly Progress Report and associated documents. The purposes of the meeting are to review and determine the status of each activity in relation to the Contractor's draft Monthly Progress Report and any deficiencies based on the Quality System as specified in Section 01470, QUALITY MANAGEMENT SYSTEM, in order to develop an informal agreement on the monthly progress payment request.
- B. The meetings shall be attended by the Contractor's Key Personnel, the Contracting Officer Representative, and other representatives of the Authority.
- C. The Monthly Progress Report and associated documents, as specified in Section 01322, CONTRACT PROGRESS REPORTING, shall be updated on a monthly basis. Job progress shall specifically include actual start and completion dates for all activities completed during the reporting period, actual start dates and percent complete for activities started but not completed during the reporting period, estimated start dates for activities scheduled to start during the next period, approved changes in durations of activities, and separate tabulation of monthly earnings including a cumulative tabulation of monthly earnings to date. In computing the monthly earnings, no value will be allowed for partially completed activities.
- D. Update the Monthly Progress Report and associated documents to incorporate all changes agreed to during the preliminary progress and quality status report meeting. A formal progress and quality status report meeting will be held prior to the submittal of the Contractor's progress payment request. The purpose of the meeting is to review and develop a formal joint agreement on the Monthly Progress Report, job progress, pay items, and quality certification. This meeting shall be held 5 working days after the preliminary progress and quality status report meeting.
- E. Submit the approved Monthly Progress Report and the progress payment request in accordance with Section 00744, METHOD OF PAYMENT.

#### 1.5 CHANGE MEETINGS

- A. Separate meetings will be held in the Washington Metropolitan Area by either the Authority or the Contractor, on an ad hoc basis, to discuss and resolve change order issues as they arise during the course of construction.
- B. This meeting shall be attended by the Contractor's Key Staff, Contracting Officer Representative, and those Subcontractors, Suppliers, or other entities critical to the resolution of any open issues. The parties shall each be represented by persons thoroughly familiar with and authorized to conclude matters relating to the Work described in the Contract Documents.

C. The Contracting Officer Representative will record meeting minutes and distribute copies to everyone in attendance and to others affected by decisions or actions resulting from each meeting.

PART 2 – PRODUCTS (not used)

PART 3 – EXECUTION (not used)

END OF SECTION

**SECTION 01321**  
**CONSTRUCTION PHOTOGRAPHS**

**PART 1 – GENERAL**

**1.1 SUMMARY**

- A. This Section includes procedural requirements for photographic documentation, including digital images.

**1.2 SUBMITTALS**

- A. Make submittals in accordance with Section 01330, SUBMITTAL PROCEDURES, and as described in Section 01322, CONTRACT PROGRESS REPORTING.
- B. Key Plan: Submit key plan 30 Days prior to start of construction. If vantage points are altered, submit key plan updates with corresponding photographic documentation submittal.
- C. Digital Still Photographs: Submit with record of photographs indicating name of photographer, identification of vantage point, date of photograph and electronic file name. Submit the following types of still photographs:
  - 1. Pre-Construction Photographs: Submit 30 Days prior to start of construction.
  - 2. Monthly Construction Photographs: Submit every 30 Days.
  - 3. Subject-specific construction photographs such as, but not limited to still photos showing potential change, non-conformance, quality, and property damage photo documentation.
  - 4. Completion of Construction Photographs: Submit within 30 Days of Notice of Substantial Completion.

**1.3 QUALITY ASSURANCE**

- A. Qualifications:
  - 1. Photographer Qualifications: Professional photographer experienced in construction photography for a minimum of 3 years.

**PART 2 – PRODUCTS**

**2.1 KEY PLAN**

- A. Indicate project site with notation of vantage points marked for location and direction of each still photograph.
- B. Include location and type and model of still camera.
- C. Include description of vantage point indicating location, direction (by compass point), and elevation.

**2.2 STILL PHOTOGRAPHS**

- A. Camera Specifications: Provide digital camera with sensor resolution of a minimum of 8 megapixels for producing color digital photographs.
- B. Format:

1. Set camera to produce a digital stamp of the current date and time on each image.
2. Provide required images in .JPG format.
3. Digital photographic files shall be capable of producing standard commercial quality photographs, 8 inches by 10 inches in size.
4. Identification:
5. Electronically label each still photograph with the following information on the bottom left corner:

WASHINGTON METROPOLITAN AREA TRANSIT AUTHORITY

Project: \_\_\_\_\_ Contract No.: \_\_\_\_\_

Contractor \_\_\_\_\_

Photograph No. \_\_\_\_\_ Date: \_\_\_\_\_

Description: \_\_\_\_\_

### PART 3 – EXECUTION

#### 3.1 GENERAL

- A. All photographic and video documentation shall be captured digitally. Submit digital images exactly as originally recorded in the digital camera, without alteration, manipulation, editing, or modifications using image-editing software.

#### 3.2 STILL PHOTOGRAPH REQUIREMENTS

##### A. Preconstruction Photographs:

1. Provide pre-construction still photographs at each site.
2. Take sufficient overlapping still photographs to show existing conditions of adjacent properties before starting the Work.
3. No construction shall begin prior to Contracting Officer Representative review and approval of the pre-construction photographs of the construction area.
4. Take still photos at locations to be disturbed or likely to be affected by construction and at locations designated by the Contracting Officer Representative.

##### B. Monthly Construction Photographs: Take still photos of construction during the progress of the Work.

1. Take a minimum of twenty still construction photos at each site every 30 Days starting after the pre-construction digital survey and continuing until Substantial Completion is achieved.

##### C. Subject-specific Construction Photographs:

1. If there are any evident changes in conditions, non-conformance in the Work, or signs of potential damage to property or constructed project, take sufficient photographs to document the conditions and no less than ten still photographs.
2. The photographer shall provide scale to the area/condition, such as a tape measure to substantiate cracking.

D. Final Completion Construction Photographs:

1. Take a minimum of twenty still photos at each site at Substantial Completion.

END OF SECTION





**SECTION 01322**  
**CONTRACT PROGRESS REPORTING**

**PART 1 – GENERAL**

**1.1 SUMMARY**

- A. This Section specifies the requirements for reporting progress and the development and maintenance of schedules and work plans for both the design and construction of the Project.
- B. The Contractor shall carefully monitor the progress of the Work during construction and provide the Authority with Monthly Progress Reports detailing the progress of that work.
- C. The approved schedules shall be used by the Contractor to ensure adequate planning, scheduling, managing, and executing of the Work, and to enable the Authority to evaluate work progress and progress payments. These approved schedules shall not be revised without the prior approval or direction of the Contracting Officer Representative. Schedules shall include the following Initial 90-Day Schedule; Project Schedule; monthly updates of the Project Schedule; 90-Day Schedule; and Three-Week Work Plan.
- D. During Outage Work construction period of 21 Days, Contractor shall provide Three-Day Look-Ahead Schedule on a daily basis.

**1.2 REFERENCES**

- A. Associated General Contractors Manual - Construction Planning and Scheduling.

**1.3 SUBMITTALS**

- A. Make the following submittals in accordance with Section 01330, SUBMITTAL PROCEDURES:
- B. Monthly Progress Status Report shall be submitted in electronic format in MS Word and Adobe (.PDF) and formatted to 8-1/2 by 11 inches or 11 by 17 inches in size.
- C. Schedule submittals including Initial 90-Day Schedule, Project Schedule and monthly updates, 90-Day Schedule, Three Week Work Plan, and Three-Day Look-Ahead schedule updates (during 21 Day Outage Work) shall be generated in Primavera Project Planner (P6) for Windows and formatted to 11 by 17 inches or 22 inches by 34 inches. Submit monthly in Primavera (.XER) and Adobe (.PDF) format and on paper media for the 90-Day Schedule or the Project Schedule, whichever is in use.
  - 1. CPM terminology, definitions, and conventions as required herein shall be consistent with the technical portions of the Associated General Contractors Manual titled Construction Planning and Scheduling.
  - 2. All schedules and reports shall be prepared and submitted in electronic format and labeled with the Contract Number, Project name, Contractor's name, data date, run date, and with any access codes or file designators listed.
- D. The Project Schedule submittal, all subsequent schedule updates, and time extension requests shall also include the following computer-generated reports:
  - 1. Successor Report: This report shall contain all activities shown on the graphic network diagram listed in ascending order of activity ID based on successor relationships.
  - 2. Predecessor Report: This report shall contain all activities shown on the graphic network diagram listed in descending order of activity ID based on their predecessor relationships.

3. Float Report: This report shall contain all activities shown on the graphic network diagram listed in order of ascending total float values and, where float values are equal, in chronological order of the early start date.
  4. Late Finish Report: This report shall contain all activities as shown on the graphic network diagram listed in chronological order of the late finish date.
- E. Contracting Officer Representative will review and return the Contractor's schedule submittal with comments according to the following schedule from the date of receipt:

Initial 90-Day Schedule	7 Days
90-Day Schedule	7 Days
Project Schedule	21 Days
Three-Week Work Plan	1 Day
Three-Day Look-Ahead	1 Day

1. The Contractor shall make all corrections to the schedule requested by the Contracting Officer Representative and resubmit the schedule for approval. If the Contractor does not agree with the Contracting Officer Representative's comments, the Contractor shall provide written notice of disagreement within 5 Days from the receipt of the Contracting Officer Representative's comments for the Project Schedule. Contracting Officer Representative's comments to the Initial 90-Day Schedule, Project Schedule, 90-Day Schedule, and Three-Week Work Plans with which the Contractor disagrees shall be resolved in a meeting held for that purpose.

F. Resubmittals shall conform to the same requirements as original submittals.

#### 1.4 MONTHLY PROGRESS REPORTS

- A. The Monthly Progress Reports shall include a narrative report, schedules, a Quality Compliance Certification and construction photographs as follows:
1. A narrative description of work accomplished, work activities planned for the upcoming reporting period, problem areas and actions intended by the Contractor to mitigate the problem areas, work that is being performed out of sequence with accepted schedules, status of change orders, notices of potential Claims, status of submittals, and status of Contractor procurement items. Proposed minor logic changes shall be listed and described in the narrative. Include narrative of design progress each month until design is complete and Approved.
  2. Schedules including the Initial 90-Day Schedule, or the Project Schedule, or the Monthly Update of the Project Schedule as appropriate; 90-Day Schedule; and a Three-Week Work Plan. Schedules shall clearly identify the critical path(s).
  3. Cash flow curves indicating graphically the total percentage of work activity/event dollar value scheduled to be in place on early finish, late finish, and actual finish on a monthly and cumulative basis.
  4. Quality Compliance Certification as specified in Section 01470, QUALITY MANAGEMENT SYSTEM.
  5. A summary of meetings or conferences held or attended during the report period.
- B. A listing of actions or decisions required of the Authority with an indication of the date by which such action or decision is required to avoid any adverse impact on the schedule.

1. Utility/Jurisdictional Authority coordination and approvals report. Include telephone conversations and dates of contact made with each Utility/Jurisdictional Authority.
2. Construction photographs, as described in Section 01321, CONSTRUCTION PHOTOGRAPHS.

#### 1.5 INITIAL 90-DAY SCHEDULE

- A. A cost loaded schedule covering the first 90 Days of the Contract shall be submitted within 20 working days following the date of the Notice of Award. The Initial 90-Day Schedule is the Contractor's plan for planning, managing, executing, and for recording completed work during the first 90-Day Days of the Project. All approved activities in the Initial 90-Day Schedule shall be incorporated into the Project Schedule.
- B. The schedule shall be time-scaled and may be submitted in either bar chart or Critical Path Method (CPM) format. The Initial 90-Day Schedule shall include the same requirements as the Project Schedule with the exception of information that is not reasonably available in the first 90-Days.
- C. Work items defined in the schedule shall not exceed 20 working days duration.
- D. The initial submittal shall be accompanied by a written narrative that describes the schedule and the approach to the Work that the Contractor intends to employ during the initial 90-Day period of the Contract.
- E. The Initial 90-Day Schedule will be used to process progress payments for the 90-Day period following NTP until the Project Schedule is Approved.

#### 1.6 PROJECT SCHEDULE

- A. A cost loaded, calendar time-scaled CPM network diagram schedule covering the complete Period of Performance of the Project shall be submitted within 60 Days following the date of the Notice to Proceed. A Project Schedule, acceptable to the Contracting Officer Representative, shall be in place prior to the third progress payment request being submitted. The original logic of the Initial 90-Day Schedule shall be incorporated into the Project Schedule unless identified changes are submitted and approved by the Contracting Officer Representative.
- B. The schedule must meet all of the dates listed under Special Conditions Section 00824, PERIOD OF PERFORMANCE AND PROJECT SCHEDULE.
- C. The Project Schedule shall be prepared utilizing the Precedence Diagram Method (PDM) of CPM scheduling technique.
- D. The Project Schedule shall show clearly the sequence and interdependence of activities and shall list specifically:
  1. Interim milestone completion dates as specified and staging of the Work shall be prominently identified.
  2. Acquisition of permits, and Jurisdictional Authority and Utility approvals
  3. Submittals and Authority review of submittals
  4. Procurement, fabrication, delivery, installation, and testing of major materials and equipment
  5. Delivery of Authority-furnished equipment, if any
  6. Interfacing, coordination, and dependencies with preceding, concurrent, and follow-on contractors

7. Work to be performed by other agencies, which affect the schedule
8. Manpower, material, and equipment restrictions, if any
9. Inspection of the Work including Punch List and Acceptance
10. The progressive delivery of Record Documents as major sections of the work are completed; for example completion of foundation piling or completion of underground utility work
11. Resources necessary to accomplish the Work for that activity including, but not limited to, specific equipment, manpower, and material requirements.
12. The costs of the work for each activity
13. The graphic network diagram shall be composed of two parts, a Table of Activity Data and a time-scaled graphic network diagram, and shall include the following:
  - a. A Table of Activity Data in columnar format with the pertinent data for each activity in the row corresponding to that activity's placement of schedule. The minimum required data are:
    - (1) Activity ID,
    - (2) Activity Description,
    - (3) Early Start date,
    - (4) Early Finish date,
    - (5) Late Start date,
    - (6) Late Finish date,
    - (7) Total Float,
    - (8) Planned Duration,
    - (9) Monetary value in whole dollars for that activity, labor-days applicable to each activity, and all lag/lead time
  - b. The Contracting Officer Representative may require additional data such as total shifts or other resource data.
  - c. An activity numbering system shall be utilized, which assigns a unique activity identification number to each activity. No two activities shall bear the same activity number or description.
  - d. Activity descriptions shall be brief but shall convey the scope of the work described. Unusual abbreviations shall be explained in a legend. If an activity includes work to be done by a Disadvantaged Business Enterprise (DBE), that fact shall be identified in the activity description by inclusion of an appropriate parenthetical entry (e.g., Install West Footing Reinforcing Steel (DBE1)) with DBE properly identified in the legend.
  - e. Percentages shall generally not be used in activity descriptions e.g., Pour West Footing (0 to 50 percent) is not acceptable.
  - f. A time-scaled graphic network diagram showing logical relationships and constraints formatted in accordance with the following requirements:

- (1) A bar (node) representing the duration of each work activity scaled to the planned duration with arrows (relationship lines) defining predecessor and successor relationships. Each bar shall contain the following information positioned above, below, or adjacent to it in a consistent and legible manner:
    - (a) activity description;
    - (b) abbreviated start and finish dates (the day of the month in which the event occurs),
    - (c) and the activity duration.
  - (2) Lag time in whole Project units (e.g. working days) shall be displayed on each relationship line where it occurs. The use of lag must be minimized and restricted to only those situations where it is not possible to properly define the start or finish of an activity by the use of a normal Finish-to-Start, Start-to-Finish, Start-to-Start, or Finish-to-Finish relationship. Negative lag shall not be used.
14. Monetary value of each activity indicated in the Schedule shall be identified in the Table of Activity Data following the description. The allocation of monetary values assigned to activities shall be subject to approval and shall contain, as close as can reasonably be determined, all labor, equipment, material, and Subcontractor cost plus its proportional share of all indirect costs. The total of all values allocated to the individual work activities shall equal the total Contract value. Should the Contractor intend to deliver materials and receive payment under the delivered Materials on Site (MOS) provision of the Contract, with the approval of the Contracting Officer Representative, the following shall be incorporated into the schedule:
- a. A MOS delivery activity shall be incorporated into the schedule in logical sequence with the associated installation activity. The cost allocated to the installation activity shall be reduced by the approved MOS activity amount. The activity description shall contain the MOS designation and an MOS activity code shall be assigned.
  - b. The monetary value assigned to that MOS activity shall be arrived at by considering only those materials the monetary values of which are to be excluded from the monetary values of the installation activities to which they relate. The monetary value of the delivery activity shall equal the projected invoiced values of materials, as restricted above and in other relevant provisions of the Contract, to be delivered to the Site. The Contractor shall submit a separate, detailed breakdown of the projected total of all MOS activities.
- E. Individual schedule activities shall not exceed 20 working days duration, except certain procurement, delivery, or MOS activities, which may exceed 20 working days with the approval of the Contracting Officer Representative. Activities exceeding 20 working days duration shall be subdivided.
- F. Schedule activities shall be sufficiently described to include what is to be accomplished and of the activity sequence (i.e. group activities by category of work, work area, and responsibility). Activity durations shall be expressed in whole days. Work that is to be performed by Subcontract shall be clearly defined.
- G. The schedule diagram shall indicate a clearly defined critical path, which shall be prominently distinguished.

- H. A written narrative shall accompany the schedule submittal describing the Contractor's approach and methods for completion of the Work. The narrative shall be adequate for the Contracting Officer Representative to understand the schedule and specifically identify the use of lag time.
  - 1. The supporting narrative shall include the following:
    - a. A realistic approach to meeting the Contract completion date required by the Contract.
    - b. A discussion of the critical path and the most critical activities in meeting the required completion dates.
    - c. A listing of holidays and special non-working days planned during the Contract duration.
    - d. A separate tabulation of estimated monthly and cumulative planned earnings. The monetary values shall be generally consistent with the proposal item breakdown.
  - I. Submit the calendar(s) used to calculate the Project Schedule, including: (i) the proposed number of working days per week; (ii) the planned number of shifts per day; (iii) the number of hours per shift; and (iv) all non-working days.
  - J. In addition to the Project Schedule, the Contractor shall submit for approval a summarized Project Schedule depicting the entire Project Schedule in graphical, time-scaled format that clearly identifies the Contractor's work areas, activities, and planned logic for completion of the Work. The summarized Project Schedule shall consist of hammocked activities or otherwise summary bars of logically-grouped activities, of approximately 300 to 500 activities total.
  - K. A schedule showing the work completed in less than the Period of Performance, which is found practical and Approved by the Authority, shall be considered to have float. The float shall be the time between the scheduled completion of the Work and the Contract completion date. Float shall not be for the exclusive benefit of either the Authority or the Contractor. Float shall be a resource available to both parties.
  - L. A schedule found to be impractical by the Contracting Officer Representative for any reason shall be revised by the Contractor and resubmitted.
  - M. Upon Approval by the Authority, the Project Schedule shall be the baseline schedule used to monitor progress.

#### 1.7 MONTHLY UPDATES OF THE PROJECT SCHEDULE

- A. At least once each month, the Contractor shall submit an updated Project Schedule showing the progress of the Work to date and anticipated activities to be worked on.
- B. The Project Schedule shall not be revised to include additional activities, deleted activities, revised activity durations, revised network logic, or any other changes to the schedule, without approval of the Contracting Officer Representative. Only actual progress, completion dates, and anticipated future progress shall be incorporated in a schedule update.
- C. If according to the current updated Project Schedule, the Contractor is 60 or more working days behind the Contract completion date of any milestone, or the schedule contains 60 or more working days of negative float, considering all granted time extensions, the Design-Builder shall submit a Recovery Schedule, showing a practical plan to complete the work within the Contract time. The Contractor shall execute some or all of the following remedial actions: (i) increase construction labor in such quantities and crafts as necessary to eliminate the backlog of work; (ii) increase the number of working hours per shift, shifts per working day, working days per week, the amount of construction equipment or any combination to eliminate the backlog of work. The Authority may withhold progress

payments until a revised schedule, acceptable to the Contracting Officer Representative, is submitted by the Contractor.

- D. Revisions to the planned sequence, activity durations, interdependency of activities and any other change to the schedule shall be submitted separately for review. Written notification and explanation for the proposed changes and separately revised Project Schedule and narrative reports shall accompany the submittal. Changes shall not be incorporated into the current schedule until the submittal has been accepted by the Contracting Officer Representative. The baseline Project Schedule, i.e., the current schedule excluding schedule changes, shall be submitted along with the proposed schedule changes for the Contracting Officer Representative's review and approval.
- E. Maintain the As-Built Project Schedule data according to the field records and submit to the Contracting Officer Representative on a monthly basis. In addition, retain all monthly schedule updates until the Work has been Accepted.
- F. After all Contract work items are complete, and as a condition of Final Payment, the Contractor shall submit three copies of an As-Built Project Schedule showing actual start and finish dates for all work activities and milestones, based on the accepted monthly updates. The schedule submittals shall be in tabular and in time-scaled PDM plot formats. See Section 00744, METHOD OF PAYMENT, for additional retainage to be withheld until the As-Built Project Schedule is delivered to the Contracting Officer Representative, is reviewed, and is determined to be complete and accurate.

#### 1.8 90-DAY SCHEDULE

- A. A schedule depicting activities occurring in the upcoming 90-Day period in greater detail than specified in the Initial 90-Day and Project Schedules. The logic shall follow the logic of the approved Project Schedule.
- B. The schedule shall be time scaled and may be submitted in either bar chart or Critical Path Method (CPM) format.
- C. Activities shall be 10 Days or less duration with particular focus on design, procurement, and associated activities to be performed in this time frame.
- D. The 90-Day Schedule shall be updated and submitted monthly for review and approval by the Contracting Officer Representative.

#### 1.9 THREE-WEEK WORK PLAN

- A. A schedule in a calendar time-scaled bar chart format depicting the Contractor's intended work activities for the upcoming 3-week period shall be submitted on a weekly basis due on the first working day of each week. Each activity having 1-day duration shall be prominently noted.
- B. Deviations, including but not limited to sequences of work, timing, and durations of activities from the Initial 90-Day or Project Schedules shall be noted and explained in writing.
- C. The form of submittal may be formatted smaller than specified in Article 1.03 herein; however, the format shall not be less than 8-1/2 by 11 inches in size.

#### 1.10 THREE-DAY LOOK-AHEAD

- A. A schedule in a calendar time-scaled bar chart format depicting the Contractor's intended work activities for the upcoming 3-Day period shall be submitted on a daily basis during the 21-Day Outage Work construction period. Each activity having 1-day duration shall be prominently noted.

- B. Deviations, including but not limited to sequences of work, timing, and durations of activities from the Project Schedules shall be noted and explained in writing.
- C. The form of submittal may be formatted smaller than specified in Article 1.03 herein; however, the format shall not be less than 8-1/2 by 11 inches in size.

PART 2 – PRODUCTS (not used)

PART 3 – EXECUTION

3.1 GENERAL

- A. Schedules shall represent a practical plan to complete the Work within the Period of Performance, and shall convey the Contractor's intent in the manner of prosecution and progress of the Work.
- B. The scheduling and executing of the Project Work in accordance with the schedule are the responsibility of the Contractor.
- C. The submittal of schedules shall be understood to be the Contractor's representation that the schedule meets the requirements of the Contract Documents and that the Work will be executed in the sequence and duration Indicated in the schedule.
- D. All schedule submittals are subject to review and acceptance by the Contracting Officer Representative. The Authority retains the right to withhold progress payments until the Contractor submits a schedule, payment schedule, and updates acceptable to the Contracting Officer Representative.
- E. The approved Project Schedule will be used as the basis for progress payments to the Contractor. Payments will be made by the Contracting Officer Representative only for activities that are 100 percent complete.

3.2 PAYMENT

- A. Submittal Monthly Progress Report at least 5 working days prior to the submittal of a progress payment request. No progress payment request will be processed if there is not an agreed update in place.

3.3 PROJECT SCHEDULER

- A. To prepare the Project schedules, the Contractor shall engage the services of a full time scheduler who is skilled in the time and cost application of scheduling using PDM network techniques for heavy construction projects.
- B. The Contractor's scheduler may or may not be an independent consultant; however, the scheduler shall be available to the Contractor and Contracting Officer Representative to address schedule questions and shall attend all Periodic Progress Review and Schedule meetings convened by the Contracting Officer Representative.
- C. In the event that the Project scheduler is not found to be competent or to have sufficient relevant experience, WMATA will request that the Project scheduler be removed from the Project pursuant to Section 00709, PROJECT MANAGEMENT AND SUPERINTENDENCE AND KEY STAFF. In that event, the Contractor shall submit a new candidate for consideration within 10 Days.

3.4 REQUESTS FOR TIME EXTENSIONS

- A. The Contractor is responsible for submitting a written request for any extensions of Period of Performance within the time specified by the Contract. Requests not submitted in writing, without the required documentation, and not submitted within 30 Days will not be considered.



- B. The request shall include documentation with written justification for the extension of time, supporting evidence, and specific references to the Contract for which the basis of the request is being made.
- C. The request shall also include a calendar time-scaled CPM network schedule analysis and reports specified in Article 1.06 herein, depicting the time impact basis of the request with the affected areas prominently highlighted. The Project Schedule to be used in determining the time extension request shall be the current and accepted schedule at the time of the event.
- D. If the Contracting Officer Representative finds that the Contractor is entitled to an extension of time of any completion date under the provisions of the Contract, the Contracting Officer Representative's determination of the total number of Days extension will be based upon the current analysis of the currently approved Project Schedule and upon data relevant to the extension. Extensions of time for performance under any and all of the provisions of the Contract will be granted only to the extent that equitable time adjustments for the activity or activities affected exceed the total float along the paths involved of the most critical path to Project completion.
- E. The Contractor shall submit a CPM fragnet with enough detail to depict the causes, duration, and logic relationship and impact of the current schedule activities. The quantum of delay impact on Contract completion or interim milestone(s) must be determined for time extension.
- F. Critical delays, i.e., delay, which may affect the activities on the current critical path, will be contemporaneously discussed and mutually agreed by all the parties involved. In case the quantum of delays or impact cannot be resolved, the background, issues, work performed, as well as start and finish dates of delays shall be well-documented in chronological order. The Contracting Officer Representative's determination of merit for time extension(s) will be awarded after the Contracting Officer Representative finds entitlement to the Contractor's request and only after the alleged delays are demonstrated to impact the most critical path(s). Data furnished by the Contractor will be used as a basis in the findings of the Contracting Officer Representative.
- G. A complete As-Built Schedule, which has enough detail to depict delay and demonstrate cause-effect delay impact, shall be submitted at the end of the Project.

END OF SECTION



**SECTION 01330**  
**SUBMITTAL PROCEDURES**

**PART 1 – GENERAL**

**1.1 SUMMARY**

- A. This Section specifies the general requirements and procedures for preparing and submitting design and construction documents to the Authority and Jurisdictional Authorities for approval or for information. The submittals shall consist of, but not be limited to design drawings, computations, and specifications; Shop Drawings; Working Drawings; product data; samples; documents, letters, certifications and reports; permit applications and Jurisdictional Authority approval documents; and other submittals.

**1.2 DEFINITIONS**

- A. Schedule of Required Submittals: A compendium of all required design and construction related submittals identified throughout the Contract Documents.
- B. Contract Document Submittal Log: A document indicating the status of all Required Submittals listed in the Schedule of Required Submittals.

**1.3 SUBMITTAL SCHEDULE**

- A. Provide a preliminary Schedule of Required Submittals, as described in Section 00720, SUBMITTALS, within 14 Days after the assignment of each task for the Authority's review. The preliminary Schedule of Required Submittals shall be updated through discussions with the Authority during weekly progress meetings or through special meetings subsequent to initial Authority approval.
- B. Submit a Contract Document Submittal Log, as described in Section 00720, SUBMITTALS, within 30 Days after the assignment of each task. The Contract Document Submittal Log, created in MS Excel or MS Access, shall consist of all submittals required by the Contract Documents. Populate the Contract Document Submittal Log with submittal data as the design and construction progresses. The Contract Document Submittal Log shall list all versions of a submittal, however only one version of a submittal may be in effect at any one time.
- C. Submit a final Schedule of Required Submittals within 30 Days after the assignment of each task.
- D. Submittals made shall be arranged and maintained in a tabular format by specification Section as well as in chronological order by the dates required for construction. The log shall include:
  - 1. Scheduled date for initial Submittal, review, and "need" date for acceptance in order to fabricate and install, corresponding to the Project Schedule activity.
  - 2. Contract number, specification Section number and title
  - 3. Name of Subcontractor
  - 4. Type of Submittal (Shop Drawings, product data, samples, or other), description of the item, name of manufacturer, trade name, and model number
  - 5. Highlight submittals that are on the critical path and require expedited review to meet the schedule. Indicate lead time to the date of fabrication and installation.
  - 6. State if submitted for approval or information.

7. If a Submittal is a safety critical item based on the approved Certifiable Items List (CIL), include the "Item" number and "Section" (paragraph) number, as shown on the Certifiable Items List.
8. Re-submittals: Reason for change
9. Tested/Inspected By: Identify the entity performing the test

E. The Contract Document Submittal Log shall be updated and submitted on a monthly basis.

#### 1.4 SUBMITTAL ADMINISTRATIVE REQUIREMENTS

- A. Submit one electronic copy in the format specified, unless noted otherwise, through the Authority's Project Management Software System (PMSS). The Contracting Officer's Representative will return one electronic copy through the PMSS.
- B. Allow 21 Days for review of submissions and resubmissions.
- C. The Contracting Officer's Representative will discard submittals received from sources other than the Contractor.
- D. Prepare separate submittals for each item in a specification Section. Group them in the order listed, paragraph by paragraph, and package them together.
- E. Transmit submittals of related parts of the Work concurrently such that processing will not be delayed for coordination. Incomplete submittals will be returned to the Contractor with no action taken by the Authority.
- F. Place a permanent label or title block on each submittal item for identification.
  1. Indicate Project name and Contract number, the date of submission, reference to the specification Section article, and drawing number and detail to which the submittal applies.
  2. Indicate name of firm or entity that prepared each submittal.
  3. Provide a blank space approximately 5 by 5 inches, in the lower right corner of each drawing just above the title block, to record the Contractor's review and approval markings and action taken by the Contracting Officer Representative.
- G. All submittals shall be accompanied with a transmittal form containing the following minimum information.
  1. Project name and Contract number, the date of submission, Subcontractor, Supplier, manufacturer name, and submittal number
  2. Submittal purpose and description
  3. Reference to the specification Section, drawing number, and title
  4. Reference applicable standards, such as ASTM or Federal Specification numbers
  5. Location(s) where product is to be installed, as appropriate
  6. Identification of deviations from the Contract Documents
  7. Notation that Submittal is a safety critical item, if identified on the "Certifiable Items List"

## 1.5 MEETING MINUTES

- A. Prepare meeting minutes that are the responsibility of the Contractor immediately after each meeting. Submit draft copy to Contracting Officer Representative for review within 5 Days in MS Word format.
- B. Submit final meeting minutes in Adobe (.PDF) format 3 Days after receipt of Authority review.

## 1.6 SHOP DRAWINGS

- A. General:
  - 1. Submit Shop Drawings in AutoCAD and Adobe (.PDF) formats. Contractor may submit Shop Drawings for equipment and materials previously approved by the Authority as long as the Shop Drawings meet the requirements of these Contract Documents. Authority will return such submittals within 7 Days of receipt as long as submittals are clearly marked as having been previously approved by the Authority and the other requirements of this paragraph are met. Shop Drawings shall indicate all pertinent features of the products and the method of fabrication, connection, erection, or assembly with respect to the Work.
  - 2. The first drawings submitted by Contractor, Subcontractor, or vendor will be reviewed for conformance with this Section. Once accepted, use the drawing format as a standard for subsequent drawings.
- B. Dimensioning: Follow applicable dimensioning and tolerance practices as specified in ANSI/ASME Y14.5.
  - 1. Prepare Project-specific information, drawn accurately to scale. Do not base Shop Drawings on reproductions of the Contract Documents or standard printed data.
  - 2. Provide sufficient dimensions on drawings so that size, shape, and location may be determined without calculation.
  - 3. Show each dimension clearly so that only one interpretation is possible. Show each dimension for a feature once.
  - 4. Text must be legible on 11 by 17-inch prints.
  - 5. Include on the Shop Drawings details necessary for the installation, maintenance, and repair of all equipment provided.

## 1.7 WORKING DRAWINGS

- A. Submit Working Drawings in AutoCAD and Adobe (.PDF) formats.
- B. Working Drawings indicate the Contractor's plan for temporary structures that will not become part of the completed Project such as decking, temporary bulkheads, support of excavation, support of utilities, groundwater control systems, and forming and falsework for underpinning; and for such other work as may be required for construction.
- C. Working Drawings and calculations shall be signed and sealed by a professional engineer registered in the jurisdiction where the work will be performed and shall convey, or be accompanied by information sufficient to completely explain the structure, machine, or system described and its intended manner of use.

## 1.8 PRODUCT DATA

- A. Submit product data in Adobe (.PDF) format.

- B. If information must be specially prepared for a submittal because standard published data is not suitable for use, submit as Shop Drawings, not as product data.
- C. Modify manufacturers' standard drawings, catalog cuts, brochures, diagrams, schedules, performance charts, illustrations, calculations, printed installation, erection, application, and placing instructions, and other descriptive data to delete information that is not applicable to the Contract. Indicate dimensions, clearances, performance characteristics, capacities, wiring and piping diagrams, and controls. Supplement standard information with additional information applicable to this Contract.
- D. Submit product data concurrent with samples.

#### 1.9 SAMPLES

- A. Submit samples for review of kind, color, pattern, and texture for a check of these characteristics with other elements and for a comparison of these characteristics between submittals and actual components as delivered and installed.
- B. Maintain sets of accepted samples at the Site, available for quality control comparisons throughout the course of construction activity. Sample sets may be used to determine conformance of construction associated with each set.
  - 1. Samples that may be incorporated into the Work are indicated in individual specification Sections. Samples not incorporated into the Work, or otherwise designated as the Authority's property, are the property of Contractor.
- C. Samples for Verification: Submit full-size units or samples of a size indicated, physically identical with material or the product proposed for use and that shows a full range of color and texture variations expected. Samples include, but are not limited to, the following: partial sections of manufactured or fabricated components; small cuts or containers of materials; complete units of repetitively used materials; swatches showing color, texture, and pattern; color range sets; and components used for independent testing and inspection.
- D. Number of Samples: Submit five sets of Samples. The Contracting Officer Representative will retain three Sample sets; the remainder will be returned. Mark up and retain one returned Sample set as a project record sample.
  - 1. Submit a single sample where assembly details, workmanship, fabrication techniques, connections, operation, and other similar characteristics are to be demonstrated.
- E. If variations in color, pattern, texture, or other characteristics are inherent in the material or product represented by a sample, submit at least three sets of paired units that show approximate limits of variations.

#### 1.10 CERTIFICATES AND CERTIFICATIONS

- A. Submit original certificates and certifications in MS Word and Adobe (.PDF) formats.
- B. Provide certificates and certifications that demonstrate proof of compliance with Contract specification requirements for products, materials, equipment, and systems.
- C. Authority Approval of a certification shall not be construed as relieving the Contractor from furnishing products that meet the specified design intent.

#### 1.11 REPORTS

- A. Submit original reports, signed and sealed by a professional engineer in the jurisdiction that the Work is to be constructed, and any related drawings in MS Word, AutoCAD and Adobe (.PDF) formats.

- B. Provide reports that demonstrate proof of compliance with Contract specification requirements. The reports include manufactured products, materials, research, equipment, systems, and test reporting in the field or laboratory.
- C. Authority Approval of submitted reports shall not be construed as relieving the Contractor from furnishing products that meet the specified design intent.

#### 1.12 DATA

- A. Submit data and any related drawings in MS Word, AutoCAD and PDF formats.
- B. Provide written and graphic information including, but not limited to, performance and design criteria, list of applicable codes and regulations, and calculations that demonstrate proof of compliance with Contract specification requirements. Provide the name and version of software used for calculations.
- C. Authority Approval of submitted data shall not be construed as relieving the Contractor from furnishing products that meet the specified design intent.

#### 1.13 CONSTRUCTION PHOTOGRAPHS

- A. All still photographic documentation of the Work shall be provided by the Contractor in digital format.
- B. For detailed submittal procedures see Section 01321, CONSTRUCTION PHOTOGRAPHS.

#### 1.14 AS-BUILT DOCUMENTS

- A. Maintain a record set of drawings and specifications that reflect as-built conditions and that are annotated to show all changes incorporated as Work progresses.
- B. As-built drawings for work that requires design by the Contractor shall be prepared by a Professional Engineer registered in the worksite jurisdiction.
- C. Submit As-Built Drawings in AutoCAD and bookmarked-by-discipline Adobe (.PDF) formats that can be plotted either as full-size or half-size drawings that are scalable.
- D. Submit approved As-Built Documents for the completed Work as specified in Section 01775, CLOSEOUT, as elements of the Work are completed and before the scheduled date of Substantial Completion.

#### 1.15 CONTRACTOR'S REVIEW

- A. Review each submittal, including all those provided by Subcontractors and Suppliers of any tier, check for coordination with other Work and for compliance with the Contract Documents. Note inconsistencies with Contract Documents. Submittals shall bear the Contractor's approval stamp and initials of the reviewer before submitting to the Authority.
- B. Each submittal transmittal form shall be signed by the Contractor with a statement, "Having checked this submission, we certify that it conforms to the requirements of the Contract in all respects, except as otherwise indicated".
- C. Do not start work where submittals are required until submittal review is completed by the Authority and Approval, if required, has been received.
- D. Identify approval methods of the various jurisdictional authorities and obtain their approvals as required.

1.16 AUTHORITY'S REVIEW

- A. The Contracting Officer Representative shall receive construction submittals from the Contractor and will distribute them within the Authority for review.

Submittal Procedures

Section 01330 – 5



1. Shop Drawings, samples, and other submission reviews by the Authority will not include checking of dimensions for potential conflicts.
  2. Approval by the Authority of a specific item will not indicate Approval of an assembly of which the item is a component.
  3. Incomplete submittals will be returned for resubmission without review.
- B. Submittals that are reviewed by the Authority will be returned to the Contractor with one of the following approval codes:
1. Code 1: Approved Without Condition or Comment.
  2. Code 2: Approved As Noted, Resubmittal Not Required. The Contractor shall comply with changes, conditions, or comments on the submittal.
  3. Code 3: Disapproved. The entire submittal is disapproved and shall be resubmitted.

#### 1.17 RESUBMISSIONS, DISTRIBUTION, AND USE

- A. Make resubmissions in same form and number of copies as initial submittal. Note the date and content of previous submittal. Clearly indicate extent of revision.
- B. Furnish copies of final submittals to manufacturers, Subcontractors, Suppliers, fabricators, installers, Jurisdictional Authorities, and others as necessary for performance of construction activities. Show distribution on transmittal forms.
- C. Retain complete copies of submittals on Site.

#### 1.18 RFI ADMINISTRATIVE REQUIREMENTS

- A. Submit one electronic copy on the RFI form provided by the Authority, through the Authority's Project Management Software System (PMSS). The Contracting Officer's Representative will return one electronic copy through the PMSS.
- B. Allow 7 Days for the review of each RFI.
- C. The Contracting Officer's Representative will discard RFIs received from sources other than the Contractor.
- D. All submittals shall be accompanied with a transmittal form containing the following minimum information.
  1. Project name and Contract number, the date of submission, and RFI number
  2. Clear statement of the question to be addressed by the Authority
  3. Reference to the specification Section, drawing number, and title that is the subject of the RFI

PART 2 – PRODUCTS (not used)

PART 3 – EXECUTION (not used)

END OF SECTION



**SECTION 01420**  
**REFERENCES**

PART 1 – GENERAL

1.1 SUMMARY

- A. This Section lists the reference standards cited in the Contract Documents, the organizations or Jurisdictional Authorities whose standards are cited, and common acronyms used in the Contract Documents.
- B. When reference is made to codes, regulations, reference standards, and specifications, the Work shall conform to the current edition as of the date of Award, unless it is superseded by Jurisdictional Authorities.

1.2 ABBREVIATIONS AND ACRONYMS

AAR	Association of American Railroads
AASHTO	American Association of State Highway and Transportation Officials
ABS	Acrylonitrile-Butadiene-Styrene
ac	Alternating Current
ACGIH	American Conference of Governmental Industrial Hygienists
ACI	American Concrete Institute
A/D	Analog to Digital
ADA	Americans with Disabilities Act
ADAAG	Americans with Disabilities Act Accessibility Guidelines
AHA	American Hardboard Association
AHDGA	American Hot Dip Galvanized Association, Inc.
AI	Asphalt Institute
AISC	American Institute of Steel Construction
AISI	American Iron and Steel Institute
AMCA	Air Moving and Conditioning Association
AMTRAK	National Railroad Passenger Corporation
ANSI	American National Standards Institute (synonymous with USASI-ASA)
API	American Petroleum Institute
AREMA	American Railway Engineering and Maintenance of Way Association
ARI	Air Conditioning and Refrigeration Institute
ASHRAE	American Society of Heating, Refrigerating and Air-Conditioning Engineers
ASME	American Society of Mechanical Engineers
ASNT	American Society of Nondestructive Testing
ASTM	ASTM International
ATBCB	Architectural and Transportation Barriers Compliance Board
AT&T	American Telephone and Telegraph Company

AWG	American Wire Gauge (synonymous with Brown and Sharpe)
AWI	Architectural Woodwork Institute
AWWA	American Water Works Association
AWS	American Welding Society
AWPA	American Wood Preservers' Association
BG&E	Baltimore Gas and Electric Company
BIA	Brick Institute of America
BLS	Bureau of Labor Statistics
B&O	Baltimore & Ohio Railroad (Division of the CSX Transportation)
BOCA	Building Officials and Code Administrators International
BTU	British Thermal Unit
BTUH	British Thermal Units Per Hour
C	Celsius (Centigrade)
CAGI	Compressed Air and Gas Institute
CE	US Army, Corps of Engineers
cfm	Cubic Feet Per Minute
CISPI	Cast Iron Soil Pipe Institute
CMU	Concrete Masonry Unit
C&O	Chesapeake and Ohio Railroad (Division of the CSX Transportation)
CONRAIL	Consolidated Rail Corporation (formerly Penn Central)
CQCS	Contractor's Quality Control System
CRSI	Concrete Reinforcing Steel Institute
CSX	CSX Transportation (formerly Chessie System, B&O, C&O, and Chesapeake & Ohio)
CTI	Cooling Tower Institute
dB	Decibel(s)
dc	Direct Current
DFT	Dry Film Thickness
DILM	Ductile Iron Pipe, Cement-Lined and Coated, Mechanical Joint
DILP	Ductile Iron Pipe, Cement-Lined and Coated, Push-On-Joint
DPST	Double Pole, Single Throw
DTS	Data Transmission System
EPA	Environmental Protection Agency
EPR	Ethylene-Propylene-Rubber
F	Fahrenheit
FAA	Federal Aviation Administration
FCCCR	Foundation for Cross-Connection Control Research of the University of Southern California Engineering Center

FHWA	Federal Highway Administration
FM	Factory Mutual Associates
FS	Federal Specifications
FED STD	Federal Standard
FTA	Federal Transit Administration (formerly UMTA)
GPH	Gallons Per Hour
GSA	General Services Administration
HOA	HAND/OFF/AUTOMATIC
HP	Horsepower
HVAC	Heating, Ventilating and Air Conditioning
IBC;	International Building Code
ICEA	Insulated Cable Engineers Association
ICI	Industrial Coatings International
ID	Inside Diameter
IEEE	Institute of Electrical and Electronic Engineers
IPS	Iron Pipe Size
ISO	International Organization for Standardization
JGB	Jackson Graham Building 600 Fifth Street, N.W. Washington, D.C. 20001
kHz	Kilo Hertz
kV	Kilovolts
kVA	Kilovolts-amperes
kW	Kilowatts
LED	Light Emitting Diode
LEED	Leadership in Energy and Environmental Design
mV	1,000 volts
mVA	1,000 volts-amperes
MCM	1,000 Circular Mils
MCP	Motor Circuit Protector
MDNR	Maryland Department of Natural Resources
METRO	Logo for the Washington Metropolitan Area Transit Authority
MNCPPC	Maryland-National Capitol Park and Planning Commission
MS	Military Specification
MSG	Manufacturers' Standard Gauge
MIL STD	Military Standard
MSHA	Maryland State Highway Administration
MSS	Manufacturer's Standardization Society of the Valve and Fitting Industry

MTPD	Metro Transit Police Department
MUTCD	Manual of Uniform Traffic Control Devices
MWAA	Metropolitan Washington Airports Authority
MWRA	Maryland Water Resources Administration (Part of MDNR)
NAAMM	National Association of Architectural Metal Manufacturers
NACE	National Association of Corrosion Engineers
NAVFAC	USN, Naval Facilities Engineering Command
NBGQA	National Building Granite Quarries Association
NBS	National Bureau of Standards
NC	Normally Closed
NCMA	National Concrete Masonry Association
NEBB	National Environmental Balancing Bureau
NEC	National Electrical Code
NEMA	National Electrical Manufacturers Association
NFPA	National Fire Protection Association
NIOSH	National Institute for Occupational Safety and Health
NO	Normally Open
NPS	National Park Service
NTP	Notice to Proceed
NTIS	National Technical Information Service
OCCB	Operations Control Center Building 600 Fifth Street, N.W. Washington, D.C. 20001 (see JGB)
OD	Outside Diameter
OS&Y	Outside Stem and Yoke
OSHA	US Department of Labor, Occupational Safety and Health Administration
PCI	Prestressed Concrete Institute
PDI	Plumbing and Drainage Institute
PE	Polyethylene
PEI	Porcelain Enamel Institute
PEI	Petroleum Equipment Institute
PEPCO	Potomac Electric Power Company
PGFD	Prince Georges County, Fire Department
PGDPW&T	Prince Georges County, Department of Public Works and Transportation
PGSCD	Prince Georges County, Soil Conservation District
PPHM	Parts Per Hundred Million
PPM	Parts Per Million
psf	Pounds Per Square Foot

psi	Pounds Per Square Inch
psig	Pounds Per Square Inch Gauge
PVC	Polyvinyl Chloride
RCRA	Resource Conservation and Recovery Act
rms	Root Mean Square
rpm	Revolutions Per Minute
ROD	Revenue Operation Date
RQD	Rock Quality Designation
SDI	Steel Deck Institute or Steel Door Institute, depending upon context in which it occurs
SMACNA	Sheet Metal and Air-Conditioning Contractors National Association
S1S	Smooth One Side
S2S	Smooth Both Sides
SJI	Steel Joist Institute
SPDT	Single Pole, Double Throw
SPST	Single Pole, Single Throw
SSPC	Steel Structures Painting Council
TBM	Tunnel Boring Machine
TCA	Tile Council of America
TGA	Thermogravimetric Analysis
UFAS	Uniform Federal Accessibility Standards
UL	Underwriters Laboratories, Incorporated
UMTA	Urban Mass Transit Administration
UPS	Unit Price Schedule or Uninterruptible Power System, depending upon context in which it occurs
USBR	US Bureau of Reclamation
USCG	US Coast Guard
USCS	US Commercial Standard
USDA/SCS	US Department of Agriculture – Soil Conservation Service
USDOT	US Department of Transportation
USGBC	US Green Building Council
USN/CD	US Navy, Chesapeake Division

PART 2 – PRODUCTS (not used)

PART 3 – EXECUTION (not used)

END OF SECTION



**SECTION 01470**  
**QUALITY MANAGEMENT SYSTEM**

**PART 1 – GENERAL**

**1.1 SUMMARY**

- A. This Section specifies the Contractor's requirements to formalize a system that documents the structure, responsibilities, and procedures required to achieve effective quality management of the Work throughout the duration of the Contract.
- B. The Quality Management System shall be consistent with ISO 9001 standard. The Contractor is not required to be ISO certified, however, certain Suppliers and manufacturers shall be certified as required in these specifications.
- C. The Quality Management System shall include a Quality Plan, Inspection and Test Plans, and corresponding procedures and forms necessary to establish, document, maintain, and execute work that conforms to the Contract Documents.
- D. Inspection and Testing shall be performed by qualified staff and laboratories as specified herein.

**1.2 REFERENCES**

- A. Federal Transit Administration (FTA)
  - 1. FTA-PA-27-5194-12.1, Quality Management System Guidelines
- B. International Organization for Standardization (ISO)
  - 1. ISO 9001 – Quality Management Systems
  - 2. ISO 10013 – Guidelines for Quality Management System Documentation
- C. U.S. national standards maintained by the U.S. National Institute of Standards and Technology (NIST) and the U.S. Naval Observatory.

**1.3 SUBMITTALS**

- A. Make submittals in accordance with Section 01330, SUBMITTAL PROCEDURES, and as noted below. Submit plans, procedures, audit schedules and certifications for Approval. Remaining submittals are for information.
- B. Quality Plan: Contract-specific Quality Plan modeled after ISO 9001 within 30 Days of NTP and with each revision. As a minimum, the following quality elements shall be included in the Quality Plan.
  - 1. Management Responsibility
  - 2. Document Control
  - 3. Subcontracting and Purchasing
  - 4. Product Identification and Traceability
  - 5. Inspection and Testing
  - 6. Inspection Measuring and Test Equipment

7. Inspection and Test Status
  8. Nonconformance
  9. Corrective Action
  10. Quality Records
  11. Quality Audits
  12. Training
- C. Quality Procedures: Procedures for each of the quality elements in the Quality Plan within 30 Days of NTP.
- D. Inspection and Test Plans/Specific: Submit Work task or component specific Inspection and Test Plans a minimum 60 Days in advance of when the covered work is scheduled to begin.
- E. Quality Reports: Submit the following reports in accordance with the approved Quality Plan and Quality Procedures.
1. Daily Quality Reports: Daily.
  2. Test Status Report: Monthly.
  3. Review and Disposition of Nonconforming Product: With each occurrence.
  4. Summary of Management Reviews: Monthly during the first 6 months after NTP and not less than quarterly thereafter.
  5. Proposed audit schedule within 60 Days of NTP.
  6. Report of audit results and completion of corrective actions within 30 Days of the completion of an Audit.
  7. Quality Compliance Certification with each Monthly Progress Report

#### 1.4 QUALITY MANAGEMENT SYSTEM REQUIREMENTS

##### A. Quality Management System

1. The Quality Management System shall be updated to improve the system as necessary throughout the Period of Performance of the Contract to reflect changes determined to be necessary by Contractor management review, Contractor internal audit, and Authority audit. Each update of the Quality Management System requires Authority Approval.
2. During the Period of Performance, exercise positive control over all of the Work, including that of subconsultants, Subcontractors, fabricators, manufacturers, installers, and Suppliers in accordance with the Quality Plan and Quality Procedures described within the approved Contractor Quality Management System.
3. The execution of the Quality Management System shall be subject to Authority audit throughout the Period of Performance of the Contract.

##### B. Quality Plan

1. The Quality Plan shall include the signatures of the Officer(s) responsible for the Contractor entity indicating their approval of the Quality Management System.

2. Quality Manager
  - a. Shall have the qualifications specified in Section 01111, CONTRACTOR KEY STAFF.
  - b. Shall perform as the Contractor's Management Representative.
  - c. Is responsible for implementing the Quality Management System and shall have the authority to stop the Work.
3. Document Control: Current version of all documents shall be managed in the Authority's Project Management Software System (PMSS). The database shall be kept current throughout the Period of Performance of the Contract.
4. Subcontracting and Purchasing
  - a. Purchased material, equipment, and services shall be controlled to ensure that they are properly integrated into the Work.
  - b. Assure that Contractor's subconsultants, Suppliers, and Subcontractors satisfactorily demonstrate and document an adequate system for managing quality to the Contractor.
  - c. Provide adequate surveillance of subconsultants, Subcontractors, and Suppliers to assure conformance with the Quality Management System and specification requirements. This surveillance shall include inspection and audit of off-Site activities of Contractor's subconsultants, Subcontractors, and Suppliers.
5. Product Identification and Traceability: The Contractor's Quality Management System shall include provisions to identify and provide traceability of products and materials where appropriate and as required in the Contract Specifications.
6. Inspection and Testing/General
  - a. Establish an Inspection and Test Plan that conforms to the Quality Management System and the Contract Specifications and that allows for tracking of actual performance of inspections and tests.
  - b. The Inspection and Test Plan shall incorporate elements of the Authority furnished Inspection Guidelines, Part 2, as needed to meet the requirements of the Quality Plan.
  - c. Testing laboratories shall be certified as required by the Contract Specifications.
  - d. The Inspection and Test Plan shall be designed to assure that testing is performed to demonstrate that components and systems perform satisfactorily in service. Testing shall be performed by qualified and experienced personnel, and using certified in accordance with approved test procedures. Tests shall incorporate acceptance limits defined by industry codes and standards or by the Issued for Construction Specifications; the more restrictive standard shall take precedence. All test results shall be documented and submitted to the Authority for review.
  - e. Provide the Authority 14 working days notice of tests except when greater notice is required in these specifications.
  - f. Include instructions necessary to implement source inspections; receiving inspections; inspection of work in progress; hold point inspections, and completion inspections.
  - g. Forms for recording test results and authorized approval signatures shall be used for all tests. Each test form shall identify the applicable specification Section, Article, and Paragraph.



- d. Quality records generated by Subcontractors, Suppliers, fabricators, and test laboratories shall be traceable to the product being supplied or fabricated and shall be provided in advance of shipment or shall be shipped with the product.
- e. Retain quality records for the duration required to meet statutory requirements.

#### 12. Quality Audits

- a. Management reviews conducted by Contractor:
  - (1) Management reviews shall occur monthly during the first 6 months of the Contract and not less than quarterly thereafter.
  - (2) Written summaries of findings and major corrective actions shall be provided to the Contracting Officer Representative within 5 Days of completion of each review.
- b. Internal quality audits conducted by Contractor:
  - (1) Internal audits shall be performed at least quarterly.
  - (2) Deficiencies in the Quality Management System, the causes of deficiencies in the Quality Management System, and the status of corrective action and preventive action, when appropriate shall be recorded in the audit results.
  - (3) Audit results shall be provided to the Contracting Officer Representative within 14 Days of the audit with a plan for corrective and preventative action.
  - (4) Provide notification of completed corrective and preventative action.

13. Training: Establish, maintain, and provide the training needs for all personnel performing activities affecting quality. Refer to Section 01820, Demonstration and Training.

#### C. Inspection and Test Plans/Specific

- 1. As a minimum, Inspection Plans shall include the following information:
  - a. A matrix of all inspections required by the Contract Specifications to be performed by Contractor, Suppliers, or Subcontractors and their frequency.
  - b. Established hold points that require work stoppage until Authority action relative to that work activity is complete.
  - c. Established witness points that identify when Authority notification is required for a Contractor work activity.
  - d. Checklists to be utilized.
- 2. As a minimum, the Test Plans shall include the following information:
  - a. A matrix of all tests required by the Contract Specifications to be performed by Contractor, Suppliers, or Subcontractors.
  - b. Samples of test reports: the test reports shall meet the minimum requirements called for in the applicable test standards specified in the Contract Specifications.
  - c. Provisions for coordinating onsite and offsite testing.

- d. Provisions for meeting the Authority notification criteria for planned tests and inspections specified to be witnessed by the Authority. Provide the Authority a minimum of 14 Days advance notice.
- e. Description of test
- f. Specification Section, Article, and Paragraph related to each test
- g. Type of test
- h. Applicable standard
- i. Test frequency
- j. Responsibility for test performance
- k. Completion status
- l. Means of tracking and recording corrective actions being taken to assure compliance with the Issued for Construction Specifications.
- m. Means for recording test results.

#### D. QUALITY REPORTS

1. Daily Quality Reports: Daily quality reports shall summarize the construction activities to the Authority, record the inspections and tests completed and the results, and record deficiencies identified, during the previous 24 hours of work. These reports shall be provided to the Contracting Officer Representative daily.
2. Test Status Report: Track and report the status of testing. Revisions, updates, and additions the test status report shall be submitted to the Contracting Officer Representative at least monthly.
3. Quality Compliance Certification: As specified in Section 00744, METHOD OF PAYMENT, the Quality Manager's Quality Compliance Certification shall be provided with each Monthly Progress Report stating that application of the Quality Management System has demonstrated that the items requested for payment have been designed or constructed to meet the design requirements and have been inspected and tested as required to comply with the Contract Documents. Work for which satisfactory records for design, testing, inspection, or other quality elements are not available, will not qualify for payment.

#### 1.5 AUTHORITY QUALITY OVERSIGHT

- A. The principal role of the Authority in the implementation of the Contractor Quality Program will be oversight of the effectiveness of the Contractor's Quality Management System including quality control and quality assurance activities. The Authority reserves the right to conduct inspection of all phases of design and construction by Authority field staff. Deficiencies discovered will be brought to the immediate attention of the Contractor including written follow-up notification.
- B. When the Authority determines that the approved Quality Management System or plans, or any portion or feature thereof, are not controlling work sufficiently for the Work to conform to the Contract Documents, Contractor shall take appropriate action to correct such deficiencies. The Contracting Officer Representative may stop the Work activities if the Quality Management System is not functioning properly due to lack of Contractor's staff or for any other Contract non-compliance.
- C. Notwithstanding the above, Authority inspection, testing, or other actions shall not constitute Acceptance of work, nor shall it relieve the Contractor of its contractual responsibilities.

D. When Authority inspection is required, add to the purchasing document the following statement:

“Authority inspection is required prior to shipment from the plant. Upon receipt of this order, promptly notify the Contracting Officer Representative, in writing, so that appropriate planning for Authority inspection can be accomplished.”

1.6 AUTHORITY AUDITS OF THE CONTRACTOR'S QUALITY MANAGEMENT SYSTEM

- A. At its sole discretion, the Authority may conduct audits, tests, and inspections in addition to those performed by the Contractor.
- B. There will be an ongoing review and evaluation of implementation of the Contractor's Quality Management System to verify that the Contractor is effectively controlling the quality of construction.
- C. Audits include audits of fabricators, Subcontractors, subconsultants, Suppliers, and third-party audits (i.e., ISO audits, trade organization certification audits, and audits required to maintain laboratory or testing accreditation).
- D. If the implementation of the Contractor's Quality Management System is determined to be ineffective by the Authority, the Authority, at its sole discretion, may withhold payment for any and all work it deems to be deficient or non-conforming to the Contract Documents. The Contractor will be expected to make whatever changes are necessary in the organization or in the Quality Management System to provide effective control of the quality of the Work.
- E. The Authority will perform audits to verify that the Contractor is effectively controlling the quality of the Work. The basis for the audits will be the Quality Management System and the Contract Documents.

PART 2 – PRODUCTS (not used)

PART 3 – EXECUTION (not used)

END OF SECTION





**SECTION 01560**  
**TEMPORARY BARRIERS AND ENCLOSURES**

**PART 1 – GENERAL**

**1.1 SUMMARY**

- A. This Section includes requirements for temporary barriers and enclosures. This Section also includes facilities for protection of occupants entering or exiting spaces during construction.

**1.2 GENERAL**

- A. Wherever necessary, shown or specified, erect and maintain signs, fences, barricades, and pedestrian bridges for the protection of public travel, the work site, adjoining property and adjoining public places.
- B. Take positive measures to prevent entry into the Site of the Work and storage areas by children, animals, and unauthorized adults and vehicles.
- C. Appropriate warning signs and instructional safety signs as specified in Section 01580, PROJECT SIGNS, shall be conspicuously posted in all areas involving construction activities. Furnish signs and attach to, as applicable, the protective devices enclosing the Contractor's work, access, operating, and platform storage and site storage/laydown areas as applicable; pedestrian sidewalks, streets, and parking lots adjacent to the work area; and excavations and openings. The storage/laydown areas as designated by the Authority, if any, and as specified in Section 01520, TEMPORARY CONSTRUCTION FACILITIES, shall be fenced and signage shall be provided to prevent unauthorized entry. Stored materials shall be bundled or tied down by the Contractor.
- D. Protective devices shall be in accordance with codes and regulations of Jurisdictional Authorities.
- E. All work pertaining to this Section shall meet ADAAG requirements.

**1.3 SUBMITTALS**

- A. Submit the following Shop Drawings in accordance with Section 01330, SUBMITTAL PROCEDURES.
  - 1. Location and fence material of fencing for pedestrian access areas.

**1.4 TEMPORARY FENCES**

- A. Provide temporary fencing within the construction area to fence off pedestrian sidewalks, streets and parking areas from operating, access and work areas and Site storage/laydown areas.
- B. Temporary fences shall be substantially constructed in a neat appearance.
- C. Working Area Wooden Fencing
  - 1. Provide 6-foot high temporary working area wooden fencing as shown or as directed and as specified. Working area wooden fencing shall serve two purposes: to protect pedestrian access areas from hazardous construction activities, and to enclose the Contractor's work, access, storage, and operating areas.
  - 2. The location of fence for pedestrian access areas adjacent to the Work area and for enclosing Contractor's work areas shall be as specified and consistent with the Contractor's approved Working Drawings for maintenance of traffic plans.

D. Working Area Chain-link Fencing

1. Provide 6-foot high temporary working area chain-link fencing as specified to fence off storage area from operating areas, and if necessary, to fence off pedestrian access areas.
2. The location of fence for pedestrian access areas adjacent to the Work area and to the storage areas shall be as specified and consistent with the Contractor's approved Working Drawings for maintenance of traffic plans.

E. Trackway Plastic Safety Fencing

1. Provide 4-foot high temporary plastic safety fencing between tracks in Authority rail yards and other non-revenue track areas to isolate workers from active tracks.

1.5 TREE AND PLANT PROTECTION

- A. Protect trees and plants not slated to be removed or replaced from construction activities.

1.6 PROTECTION OF UTILITIES

- A. Protect existing utilities.

1.7 PROTECTION OF EXISTING STRUCTURES AND IMPROVEMENTS

- A. Protect Existing Structures and Improvements.

PART 2 – PRODUCTS

2.1 MATERIALS

- A. Barricades shall be substantial in character, neat in appearance, and of approved size and arrangement.
- B. Barricade materials shall be as approved. Lumber for barriers as applicable and working area wooden fencing shall be exterior grade, treated to be fire-retardant, pressure impregnated with resin salt as approved. Exterior latex paint for barriers and working area wooden fencing shall be as specified in Section 09920, FIELD PAINTING. Color shall be as approved by the Contracting Officer Representative. Provide necessary fencing hardware, locks, gates and all other incidentals as approved.
- C. All chain-link fencing shall be anti-climbing type, with plastic inserts, barbed wire (where indicated), and as specified in Section 02820, FENCING.
- D. Temporary fencing on Authority property between adjacent tracks: Plastic safety fencing, orange in color, supported by oak stakes embedded a minimum of two feet below subgrade.
- E. Warning signage shall be as specified in Section 01580, PROJECT SIGNS.
- F. Structural lumber for decking shall be as specified in Section 01530, TEMPORARY CONSTRUCTION.

PART 3 – EXECUTION

3.1 INSTALLATION

- A. As removal of pavement and sidewalk progresses as applicable and furnish and install barricades in accordance with requirements of the Jurisdictional Authorities. During the prosecution of the Work, barricade or close excavations and openings in floors, walls, and other parts of the structures and excavations while such openings are not in regular use as applicable. Barricade or

- close such openings before Acceptance of the Work. Barricades shall be anchored to the ground on all sides of excavations. Work involving electrical systems or equipment in or near the area to which personnel or the public have access shall be isolated using barricades.
- B. Flashing yellow lights shall be mounted and maintained on barricades at maximum intervals of 25 feet.
  - C. Fabricate and erect in accordance with local requirements pedestrian barriers as applicable and working area wooden fencing with a stud framework and a covering of tightly fitted plywood sheets. Paint with two coats of exterior latex paint. Install hardware, locks, gates, and all other incidentals. Furnish and install wooden fence along sides of decked areas for pedestrian walkways as applicable where such walkways are adjacent to open areas, staging/storage areas, and other areas used by the Contractor.
  - D. Erect chain-link fencing consisting of a post-and-rail framework with chain-link fabric; install hardware, locks, gates, and all other incidentals; and insert plastic inserts into the chain link fence.
  - E. Along sides of decked areas for pedestrian walkways as applicable, where such walkways are adjacent to vehicular traffic, install concrete barriers as shown on approved maintenance of traffic plan.
  - F. Erect, fabricate, attach, and maintain safety warning and other signs.
  - G. Protect existing vegetation, structures, utilities, and improvements.
  - H. Provide maintenance for all barricades, barriers, temporary fences, pedestrian bridges, signage, and existing vegetation, structures, utilities, and improvements protection as applicable for the duration of the Contract. Immediately prior to completion of the Contract, completely remove the items and restore the area.

END OF SECTION



**SECTION 01570**  
**TEMPORARY CONTROLS**

PART 1 – GENERAL

1.1 SUMMARY

- A. This Section includes security, site, environmental, construction noise, vibration, pollution abatement, use of explosives, and controls and management of historical and scientific specimens required to allow construction to proceed.

1.2 REFERENCES

- A. U.S. Code, Title 42 (The Public Health and Welfare):
1. Chapter 15B (Air Pollution Control), Section 1857, et seq., as amended by Pub. L. 91-604)
  2. U.S. Code, Title 33 (Navigation and Navigable Waters):
  3. Chapter 26 (Water Pollution Prevention and Control), Section 308 (33 U.S.C. 1251 et seq., as amended by Pub. L. 92-500)
- B. Society of Automotive Engineers, Inc., SAE J366b and SAE J952b

1.3 SUBMITTALS

- A. Submit the following for approval 60 Days prior to start of construction in accordance with Section 01330, SUBMITTAL PROCEDURES, and with the additional requirements as specified for each:
1. All necessary Working Drawings, specifications, permits, and certifications necessary to comply with local Jurisdictional Authority's erosion and sediment control statutes, ordinances, and requirements including, but not limited to current DC Standards and Specifications for Soil Erosion and Sediment Control (DC E&S).
  2. Required evidence that the governing air pollution criteria will be met. These criteria and related documents will be retained by the Authority for on-Site examination by FTA as applicable.
  3. Program for pollution control prior to beginning operations
  4. Proposed haul routes.

1.4 SITE SECURITY

- A. Contractor is responsible for Site security during the work hours. Authority is responsible for Site security during non-working hours.

1.5 EROSION AND SEDIMENT CONTROL

- A. Erosion and sediment materials: No erosion or sediment materials shall be allowed to enter natural or man-made water or sewage removal systems. Erosion materials from excavations, borrow areas, or stockpiled fill shall be contained within the Site. Develop methods to control waste and erosion including such means as filtration, settlement, and manual removal.
- B. Comply with and provide all necessary drawings, specifications, permits, and certifications necessary to comply with local Jurisdictional Authority's erosion and sediment control statutes,

ordinances, and requirements including, but not limited to current DC Standards and Specifications for Soil Erosion and Sediment Control (DC E&S).

## 1.6 POLLUTION ABATEMENT

- A. Conduct operations in a manner to minimize pollution of the environment surrounding the area of work. Specific controls shall be applied as follows:
1. Material transport: Trucks leaving the Site and entering paved public streets shall be cleaned of mud and dirt clinging to the body and wheels of the vehicle. Trucks arriving and leaving the Site with materials shall be loaded so as to prevent dropping materials and debris on the streets. Trucks carrying dirt from the Site shall have their loads covered to minimize fugitive dust. Maintain a suitable vehicle cleaning installation and inspection installation with permanent crew for this purpose. Spills of materials in public areas shall be removed immediately.
  2. Waste materials: No waste materials shall be allowed to enter natural or man-made water or sewage removal systems. Develop methods to control waste including such means as filtration, settlement, and manual removal.
  3. Burning: No burning of waste will be allowed without written permission from the Authority. When permission is granted, burning shall be conducted in accordance with the regulations of the Jurisdictional Authority. Submit request to the affected jurisdiction for approval.
  4. Dust control: By water sprinkling or by other approved methods, continuously control dust generated by construction operations.
  5. Noise control: Refer to Article 1.08 below.
  6. Submit evidence that the governing air pollution criteria will be met. These criteria and related documents will be retained by the Authority for on-Site examination by FTA as applicable.
  7. Submit a program for pollution control that is in compliance with the Air Act and the Water Act prior to beginning operations.
  8. Clean air and water:
    - a. The Contractor agrees as follows:
      - (1) To comply with all the requirements of Section 114 of the Clean Air Act, as amended (42 U.S.C. 1857, et seq., as amended by Pub. L. 91-604) and Section 308 of the Federal Water Pollution Control Act (33 U.S.C. 1251 et seq., as amended by Pub. L. 92-500), respectively, relating to inspection, monitoring, entry, reports and information, as well as other requirements specified in Section 114 and Section 308 of the Air Act and the Water Act, respectively, and all regulations and guidelines issued there under before the award of this Contract.
      - (2) That no portion of the Work required by this Contract will be performed in a Facility listed on the Environmental Protection Agency List of Violating Facilities on the date when this Contract was awarded unless and until the EPA eliminates the name of such Facility or Facilities from such listing.
      - (3) To use its best management practices to comply with clean air standards and clean water standards at the Facility in which or Site on which the Work is being performed.
    - b. The terms used in this Article have the following meanings:
      - (1) The term Air Act means the Clean Air Act, as amended (42 U.S.C. 1857 et seq., as amended by Pub. L. 91-604).

- (2) The term Water Act means Federal Water Pollution Control Act as amended (33 U.S.C. 1251 et seq., as amended by Pub. L. 92-500).
- (3) The term Clean Air Standards means any enforceable rules, regulations, guidelines, standards, limitations, orders, controls, prohibitions or other requirements which are contained in, issued under or otherwise adopted pursuant to the Air Act or Executive Order 11738, an applicable implementation plan as described in Section 110(d) of the Clean Air Act (42 U.S.C. 1857c-5(d)), an approved implementation procedure or plan under Section 111(c) or Section 111(d), respectively, of the Air Act (42 U.S.C. 1857c-6(c) or (d)), or an approved implementation procedure under Section 112(d) of the Air Act (42 U.S.C. 1857c-7(d)).
- (4) The term Clean Water Standards means any enforceable limitation, control, condition, prohibition, standard or other requirement, which is promulgated pursuant to the Water Act or contained in a permit issued to a discharger by the EPA or by a State under an approved program, as authorized by Section 402 of the Water Act (33 U.S.C. 1342), or by local government to ensure compliance with pretreatment regulations as required by Section 307 of the Water Act (33 U.S.C. 1317).
- (5) The term compliance means compliance with Clean Air or Water Standards. Compliance shall also mean compliance with a schedule or plan ordered or approved by a court of competent jurisdiction, the EPA or an air or water pollution control agency in accordance with the requirements of the Air Act or Water Act and regulations issued pursuant thereto.
- (6) The term Facility means any building, plant, installation, structure, mine, vessel, or other floating craft, location or site of operations, owned, leased, or supervised by Contractor or Subcontractor, to be utilized in the performance of a contract or subcontract. Where a location or site of operations contains or includes more than one building, plant installation, or structure, the entire location or site shall be deemed to be a Facility except where the Director, Office of Federal Activities, Environmental Protection Agency, determines that independent Facilities are co-located in one geographical area.

#### 1.7 ENVIRONMENTAL CONTROL

- A. Maintain temperature and humidity to protect the Work in progress and in place, as well as permanent equipment and materials, stored and installed, against damage from heat, cold, and dampness and take such steps as necessary to protect such work from other adverse conditions.

#### 1.8 CONSTRUCTION NOISE CONTROL

- A. Noise control: Take every action possible to minimize the noise caused by construction operations. When required by Jurisdictional Authorities, noise producing work shall be performed in less sensitive hours of the day or week as directed. Noise produced by the Work shall be maintained at or below the decibel levels specified and within the periods specified.

1. Protection of the public and employees:

- a. Noise abatement measures and precautions shall be taken in order to reduce exposure to noise. Permissible noise exposure shall be calculated in accordance with the procedures established under the Walsh-Healy Public Contracts Act. Sound levels for public noise exposure due to construction will be measured at the property line of adjacent residential, commercial, or industrial property or at the property line of the public right-of-way, or 50 feet from the noise source, whichever is greatest, when work is in progress in the public right-of-way, while construction work is in progress. Employee noise exposure levels shall be measured at the employees' normal workstation. In either case sound levels shall not exceed the following:

<b>Exposure per Day (hours)</b>	<b>Sound Level (dBA)</b>
8	90
6	92
4	95
3	97
2	100
1-1/2	102
1	105
1/2	110
1/4 or less	115

- b. Above-ground, repetitive, high-level impact noise will be permitted only between 8:00 AM and 9:00 PM. Repetitive impact noises in the receiving property shall not exceed the following dB limitations:

<b>Duration of Impact Noise</b>	<b>Commercial or Residential Zone</b>	<b>Industrial Zone</b>
More than 12 minutes in any hour	70	77
Less than 30 seconds in any hour	85	92
Less than 3 minutes in any hour	80	87
Less than 12 minutes of any hour	75	82

- c. In underground or tunnel construction work, where the above requirements may not be obtained, provide individual auditory protection.
2. Noise restrictions at affected property: In addition to the provisions of Article 1.02A.1 above, sound level for noise due to construction activities shall be monitored at the property line of property affected acoustically by the Contractor's operations and plant. Sound levels for noise from equipment shall be measured at the property line on the A-weighting network of a General Purpose sound level meter at slow response. To minimize the effect of reflective sound waves at buildings, measurements may be taken 3 to 6 feet in front of any building face.

- a. Construction equipment: Sound levels for unscheduled, intermittent, short-term noise from equipment shall not exceed the following dBA levels:

(1) Residential Property

- (a) Daily, 7:00 AM to 9:00 PM: 75 dBA
- (b) Daily, 9:00 PM to 10:00 PM: 55 dBA
- (c) Daily, 10:00 PM to 7:00 AM: 50 dBA

(2) Business, Industrial, and Commercial Property:

- (a) Daily, including Sundays and Legal Holidays, 7:00 AM to 9:00 PM: 82 dBA



- (b) Daily, including Sundays and Legal Holidays, 9:00 PM to 7:00 AM: 62 dBA
- b. Mobile equipment in the public right-of-way: Truck or other powered equipment, which moves off the Site in the public right-of-way and that produces a maximum sound level exceeding the following limits when moving in the public right-of-way shall not be used on this Contract. The sound level limits specified are referenced to a distance of 50 feet from the equipment. Sound levels shall be measured in conformity with the Standards and Recommended Practices established by the Society of Automotive Engineers, Inc., including the latest revisions to SAE J366b and SAE J952b.
  - (1) Mobile construction and industrial machinery as defined in Article 1.08A.3 below:
    - (a) Sound Level Limits
      - (i) Manufactured before July 1, 1975: 90 dBA
      - (ii) Manufactured after July 1, 1975: 80 dBA
      - (iii) Manufactured after July 1, 1982: 77 dBA
    - (2) Trucks:
      - (a) Sound Level Limits
        - (i) Manufactured before July 1, 1975: 88 dBA
        - (ii) Manufactured after July 1, 1975: 83 dBA
        - (iii) Manufactured after July 1, 1982: 80 dBA
  - c. Noise abatement measures: Provide such equipment and sound-deadening devices and take such noise abatement measures that are necessary to comply with the requirements of this Contract, consisting of, but not limited to the following:
    - (1) Shields or other physical barriers to restrict the transmission of noise.
    - (2) Soundproof housings or enclosures for noise-producing machinery.
    - (3) Efficient silencers on air intakes for equipment.
    - (4) Efficient intake and exhaust mufflers on internal combustion engines.
    - (5) Lining of hoppers and storage bins with sound-deadening material.
    - (6) Conducting truck loading, unloading and hauling operations so that noise is kept to a minimum.
    - (7) Routing of construction equipment and vehicles carrying spoil, concrete, or other materials over streets that will cause the least disturbance to residents in the vicinity of the Work. The Contracting Officer Representative shall be informed in writing in accordance with Section 01330, SUBMITTAL PROCEDURES, of the proposed haul routes prior to the Contractor's securing a permit from the local government.
    - (8) Siting of stationary equipment shall be subject to Approval in accordance with Section 01520, TEMPORARY CONSTRUCTION FACILITIES.
- 3. Definitions: The following definitions shall be used in differentiating mobile equipment from stationary equipment:

- a. Mobile construction equipment: Any motorized vehicle powered by an internal combustion engine or electric drive, which is capable of being operated as a vehicle either on the construction Site or in the public right-of-way.
  - (1) Construction equipment is mobile equipment any time it is operated in an automotive mode when performing construction tasks. Such equipment includes compactors, paving machines, front-end loaders, back hoes, scrapers, pavers, ditchers, and trucks.
  - (2) Some construction equipment while in transit may have the characteristic of mobile equipment, but for the purposes of this definition are not to be so considered. Such equipment includes generators, power shovels, cranes, pile drivers, drilling rigs, concrete mixers, pumps, trash compactors, bar benders, and other similar truck-mounted devices.
- b. Stationary construction equipment: Any device, tool, or other mechanical system powered by an internal combustion engine, pneumatic engine, or electric motor, which does not employ any of the above power sources for automotive propulsion for more than 10 minutes out of every working hour while engaged in construction tasks. Examples of such equipment include truck-mounted compressors, generators, power shovels, pile drivers, cranes, drilling rigs, concrete mixers, pumps, trash compactors, bar benders, augers, and other similar truck-mounted devices.

#### 1.9 CONSTRUCTION VIBRATION CONTROL

- A. Do not cause or permit, beyond the property line of a source, vibration of sufficient intensity to cause another person to be aware of the vibration by such direct means as sensation of touch or visual observation of moving objects. The observer shall be located at or within the property line of the receiving property when vibration determinations are made. Prepare and submit in accordance with Section 01330, SUBMITTAL PROCEDURES, a plan indicating monitoring locations, including the timing of monitoring measurements to be taken at the construction Site boundaries and at nearby residential, commercial, and industrial property lines. Comply with vibration limitation requirements of environmental reports, if provided.

#### 1.10 EXPLOSIVES

- A. The use of explosives for the performance of Contract work will not be permitted.

#### 1.11 HISTORICAL AND SCIENTIFIC SPECIMENS

- A. Articles of historical or scientific value, including, but not limited to, coins, fossils, and articles of antiquity, which may be uncovered by the Contractor during the progress of the Work, shall become the property of the Authority. Work in the area where discovered shall cease, and such findings shall be reported immediately to the Contracting Officer Representative in accordance with Section 01330, SUBMITTAL PROCEDURES, who will determine the method of removal, where necessary, and the final disposition thereof.

PART 2 – PRODUCTS (not used)

PART 3 – EXECUTION (not used)

END OF SECTION

**SECTION 01580**  
**PROJECT SIGNS**

PART 1 – GENERAL

1.1 SUMMARY

- A. This Section includes the requirements for Project signs that will be required at the Site during the construction of the Project.

1.2 PROJECT IDENTIFICATION SIGNS

- A. Furnish Authority Project identification signs in the locations at the Site selected by the Contracting Officer Representative.
- B. Sign size, content, lettering, and format for the large permanent-mount WMATA sign shall be as directed by the Authority.
  - 1. Refer to Contract Drawings for signage details.
- C. Signs shall be installed 20 Days after Notice to Proceed is given, shall be maintained during the Work, shall be moved from one site to the next until the Work is complete and shall be removed upon the completion of the Project.

1.3 WARNING SIGNS AND INSTRUCTIONAL SAFETY SIGNS

- A. Provide "No Trespassing" signs, and other warning and instructional safety aluminum signs with minimum 2-inch high Helvetica Medium style lettering and mount at locations on fencing/barriers/barricades/pedestrian bridges and on other areas as directed. Sign panel size and thickness shall be as directed. Mount the signs with stainless-steel cap screws with hex nuts and lock washers.

PART 2 – PRODUCTS (not used)

PART 3 – EXECUTION (not used)

END OF SECTION



**SECTION 01610**  
**BASIC PRODUCT REQUIREMENTS**

**PART 1 – GENERAL**

**1.1 SUMMARY**

- A. This Section includes administrative and procedural requirements governing the Contractor's selection of products for use in construction of the Project.
- B. Administrative procedures for handling requests for substitutions made after award of the Contract are included under Section 01630, PRODUCT SUBSTITUTION PROCEDURES.

**1.2 DEFINITIONS**

- A. As used herein, the term brand name includes identification of products by make and model. If items called for in the Contract Documents have been identified by a brand name or equal description, such identification is intended to be descriptive, but not restrictive, and is to indicate the quality and characteristics of products that will be satisfactory. Contract Specifications identifying equal products including products of the brand name manufacturer other than the one described by brand name as specified in Section 01630, PRODUCT SUBSTITUTION PROCEDURES, will be considered if such products are clearly identified and are determined by the Authority to meet fully the salient characteristics of the products specified in the Contract Documents.

**1.3 SUBMITTALS**

- A. Submit for review an initial product list in accordance with Section 01330, SUBMITTAL PROCEDURES. A written explanation for omissions of data and for known variations from Contract requirements shall be included.
- B. Submit for review and Approval a completed product list including a written explanation for omissions of data and for variations from Contract requirements within 30 Days after date of commencement of the construction work. Authority will notify Contractor of acceptance or rejection of the documentation within 21 Days of receipt of the submittal.
- C. Authority Acceptance of the product list does not constitute a waiver of the requirement that products comply with the Contract Documents.

**1.4 QUALITY ASSURANCE**

- A. Provide products of the same kind from a single source.
- B. Except for required labels and operating data, the manufacturer's or producer's nameplates or trademarks shall not be attached or imprinted on exposed surfaces.
  - 1. Labels: Locate required product labels and stamps on a concealed surface or, where required for observation after installation, on an accessible surface that is not conspicuous.
  - 2. Equipment Nameplates: Provide a permanent nameplate on each item of service connected or power-operated equipment. The nameplate shall contain the following information and other essential operating data:
    - a. Name of product and manufacturer
    - b. Model and serial number
    - c. Capacity

- d. Speed
- e. Ratings

#### 1.5 PRODUCT DELIVERY, STORAGE, AND HANDLING

- A. All products shall be delivered, stored, and handled in accordance with the manufacturer's recommendations so as to prevent damage, deterioration, loss, or invalidation of the manufacturer's warranty.
- B. Schedule delivery to minimize long-term storage at the Site and to prevent overcrowding of construction storage and staging areas.
- C. Coordinate the time of delivery with the installation schedule to ensure that hazardous, easily damaged, or those items sensitive to deterioration, theft, and other losses are stored for a minimum holding period.
- D. Products shall be delivered to the Site in the manufacturer's original sealed container or other appropriate packaging, complete with labels and instructions for handling, storing, unpacking, protecting, and installing.
- E. Products shall be inspected upon delivery by the Contractor to ensure compliance with the Contract Documents, and to ensure that products are undamaged and properly protected. Documentation noting the time, date, and manner of delivery shall be maintained by the Contractor. A statement attesting to the inspection of the products at time of delivery shall be included in the documentation signed by the Contractor's authorized representative.
- F. Products shall be stored at the Site in a manner that will facilitate inspection and measurement of quantity or counting of units. Heavy materials shall be stored in a manner that will not damage supporting construction. Products subject to damage by the elements shall be stored under cover in weather-tight enclosures with ventilation adequate to prevent condensation. Temperature and humidity shall be maintained within range required by manufacturer's instructions.

### PART 2 – PRODUCTS

#### 2.1 PRODUCT SELECTION

- A. Provide products that comply with the Contract Documents. All products to be installed in the Work shall be undamaged and, unless otherwise permitted, unused at the time of installation. Products shall include all accessories, trim, finish, safety guards, and other devices and details needed for a complete installation and suitable for the intended use.
- B. Unless otherwise specified, provide standard products of the type that have been produced and used successfully in similar situations on other Authority projects of a similar nature.
- C. Procedures governing product selection include:
  - 1. Where only a single product or manufacturer is named and the notation "no substitution is permitted" is included in the specification, provide the product indicated. No substitutions will be permitted.
  - 2. Where two or more products or manufacturers are named followed by the notation "no substitutions are permitted" is included in the specification, provide one of the products indicated. No substitutions will be permitted.
  - 3. Where the Contract Documents list products or manufacturers that are available and acceptable for incorporation into the Work, accompanied by the term "...or equal or ...or approved equal, the Contractor may propose any available product that complies with

Contract requirements: Comply with the requirement of Section 01630, PRODUCT SUBSTITUTION PROCEDURES, to obtain approval for use of an unnamed product.

4. Where the Contract Documents list the salient features that explicitly describe a product or assembly and a brand name is not included, provide a product or assembly that provides the listed features and otherwise complies with the Contract requirements.
5. Where the Contract Documents explicitly require compliance with performance requirements, and the product complies with those requirements based on the manufacturer's recommended use of the product for the application indicated in the Contract Drawings (as evidenced in published product literature, or by the manufacturer's certification of performance), the Contractor may submit the product for incorporation into the Work.
6. Where the Contract Documents require only compliance with an imposed code, standard, or regulation, the Contractor may select a product that complies with the standards, codes, or regulations specified.
7. Visual Matching: Where specifications require matching an established item, the Authority's decision will be final on whether a proposed product matches satisfactorily. Where no product is available that adequately matches adjacent products or complies with the other specified requirements, comply with provisions of Section 01630, PRODUCT SUBSTITUTION PROCEDURES, for selection of an alternate product.
8. Where specified product requirements include the phrase ...as selected from manufacturer's standard colors, patterns, textures..., select a manufacturer that provides a range of colors in a product that meets all other Contract Document requirements. In this situation, standard shall imply regularly or routinely produced.

## PART 3 – EXECUTION

### 3.1 PRODUCT LIST

- A. Prepare a product list in tabular form acceptable to the Authority showing products specified in the Contract Documents. Coordinate the timing of delivery of products on the product list with the Contractor's Project Schedule as specified in Section 01322, CONTRACT PROGRESS REPORTING, and Contract Document Submittal Log as specified in Section 01330, SUBMITTAL PROCEDURES. At a minimum, provide the following information for each product:
  1. Related specification Section number
  2. Generic name used in the Contract Documents.
  3. Proprietary name, model number, and similar designation
  4. Manufacturer's name and address
  5. Supplier's name and address
  6. Installer's name and address
  7. Projected delivery date and length of delivery period
- B. Within 14 Days of receipt of product list submittals, Contracting Officer Representative will notify the Contractor of Authority acceptance or rejection of the product list. If rejected, product list shall be corrected by the Contractor and resubmitted for review.

### 3.2 INSTALLATION OF PRODUCTS

- A. Comply with the manufacturer's instructions and recommendations for installation of all products installed under this Contract unless otherwise specified. Products shall be accurately located, aligned with other elements of the Work, and securely installed in place. All exposed surfaces shall be clean as specified in Section 01740, CLEANING, and protected as necessary to prevent damage and deterioration as specified in Section 01723, PROTECTION OF ADJACENT CONSTRUCTION.

END OF SECTION



**SECTION 01630**  
**PRODUCT SUBSTITUTION PROCEDURES**

**PART 1 – GENERAL**

**1.1 SUMMARY**

- A. This Section includes administrative and procedural requirements for handling requests for substitutions made after award of the Contract.
- B. Other requirements governing the Contractor's selection of products and product options are included under Section 01610, BASIC PRODUCT REQUIREMENTS.

**1.2 DEFINITIONS**

- A. Definitions used in this Section are not intended to change the meaning of other terms used in the Contract Documents.
- B. Contractor requests for changes in products, materials, equipment, and methods of construction as required or specified by Contract Documents are considered requests for substitutions. The following are not considered substitutions:
  - 1. Revisions to Contract Documents requested by the Authority.
  - 2. Specified options of products and construction methods included in Contract Documents. Note that products submitted under an or equal or not limited to provision are considered to be substitutions as specified in Section 00210, SUPPLEMENTARY INSTRUCTIONS TO BIDDERS.
  - 3. The Contractor's determination of and compliance with governing regulations and orders issued by governing authorities.

**1.3 SUBMITTALS**

- A. Requests for substitution from the Contractor during construction will be considered by the Authority if received with adequate time to allow for Authority review and Approval without delaying the Project Schedule. Requests received that may delay the Project Schedule will be considered or rejected at the sole discretion of the Authority.
  - 1. Submit one electronic copy in Adobe (.PDF) file format of the Brand Name or Equal Form, Section 00433, BRAND NAME OR EQUAL FORM, for each request for substitution to the Contracting Officer Representative for consideration of the form and in accordance with procedures required for Change Order proposals as specified in Section 00748, CHANGES, as deemed appropriate by the Contracting Officer Representative.
  - 2. In each substitution request, identify the product and fabrication or installation method to be replaced. The related WMATA Standard Specification Section or Contract Drawing numbers shall be referenced in the submittal. Complete documentation showing compliance with the requirements for substitutions shall also be submitted including the following information as appropriate:
    - a. Product Data, including drawings, fabrication, and installation procedures
    - b. Samples, where samples of the specified product are requested
    - c. A detailed comparison of significant qualities/salient features of the proposed substitution with those of the material or work specified. Significant qualities shall include elements

such as size, weight, durability, performance, visual effect, code compliance, maintenance requirements, energy usage, and environmental considerations.

- d. Coordination information, including a list of changes or modifications made necessary to other parts of the Work and to construction performed by the Authority or separate contractors.
- e. A statement indicating the substitution's effect on the Contractor's Construction Schedule. Indicate the effect of the proposed substitution on overall Period of Performance.
- f. Cost comparison between the product specified and the requested substitution, including a proposal of the net change, if any in the Contract Price.
- g. Certification by the Contractor that the substitution proposed is equal to or better in every respect to that required under the Contract, and that the product will perform as intended. Include a waiver of rights to additional payment or time that may subsequently become necessary should the product fail to perform adequately, or because of changes to other work were required as a consequence of the substitution.
- h. Failure by the Contractor to include the above requirements in the submittal may be cause for rejection of the submittal in its entirety.
- i. If deemed necessary and within 14 Days of receipt of the submittal, the Contracting Officer Representative may request additional information or documentation that, in its sole judgment is required for the evaluation of the substitution request. Within 21 Days of receipt of the original substitution request or of requested additional information or documentation, the Contractor will be notified of acceptance or rejection of the proposed substitution. If a decision on the use of a proposed substitute cannot be made or obtained within the time allocated, the product specified by name in the Contract Documents shall be used.

#### 1.4 SUBSTITUTION PROCEDURE

- A. The Contractor's request for substitution may be rejected by the Contracting Officer Representative if the substitution would involve:
  1. Extensive revisions to Contract Documents
  2. A proposed change not in keeping with the general intent of Contract Documents
  3. An untimely request, not fully documented when submitted
  4. A request that is directly related to an or equal clause or similar language in the Contract Documents
  5. A product or method of construction that could not be provided within the Period of Performance
  6. A product or method of construction that could not be approved by a governing authority
  7. Additional responsibilities or expense to the Authority (including additional expenses for redesign and evaluation services, increased cost of related construction, and other similar considerations) that outweighs any advantage that is being offered to the Authority as a result of the substitution
  8. A method of construction that cannot be provided in a manner that is compatible with other materials, the product cannot be coordinated with other materials, and a warranty cannot be provided for the product in accordance with the requirements of the Contract even though the Contractor expresses a willingness to certify that the apparent deficiencies can be corrected.

- B. Neither the Contractor's submittal nor the Authority's review or Approval of Shop Drawings, product data, or samples that relate to a substitution constitutes an Approval of the requested substitution. Submission of Shop Drawing, product data, or sample submittals does not relieve the Contractor from fulfilling Contract requirements for substitutions.

PART 2 – PRODUCTS (not used)

PART 3 – EXECUTION (not used)

END OF SECTION



**SECTION 01711**  
**ACCEPTANCE OF CONDITIONS**

**PART 1 – GENERAL**

**1.1 SUMMARY**

- A. This Section specifies basic requirements for determining acceptable conditions for installation.

**1.2 SUBMITTALS**

- A. One electronic copy of the preconstruction inspection records

**1.3 PRECONSTRUCTION INSPECTION REQUIREMENTS**

- A. Prior to beginning construction work, the Contractor shall inform the Authority of buildings or structures on which it intends to perform work or which performance of the Work will affect.
- B. Conditional inspection of buildings or structures in the immediate vicinity of the Project, which may reasonably be expected to be affected by the Work, will be performed jointly by the Authority and the Contractor. This inspection will be conducted prior to the commencement of construction work to determine pre-existing conditions. After this inspection, the Authority will not assume any responsibility for damages arising from the Work performed and it shall be the responsibility of the Contractor to correct all damages caused by performance of the Work.
- C. Examine substrates, areas, and conditions, with Authority personnel present, for compliance with requirements for installed tolerance and other conditions affecting performance. Record observations from the required preconstruction inspection.
- D. Where a written inspection report requires listing conditions detrimental to performance of the Work, include the following:
  - 1. Description of the Work
  - 2. List of detrimental conditions, including substrates
  - 3. List of unacceptable installation tolerances
  - 4. Recommended corrections

**1.4 EXAMINATION**

- A. General: Verify dimensions shown on existing work and dimensions required for work that is to connect with work not in place in accordance with Section 01721, LAYOUT OF WORK AND FIELD ENGINEERING.
- B. Existing Conditions
  - 1. The existence and location of Site improvements, above and below-ground utilities, and other construction indicated as existing are not guaranteed. Before beginning work, investigate and verify the existence and location of above and below-ground utilities, mechanical and electrical systems, and other construction affecting the Work. Verify the location and point of connection of utility services.
  - 2. Before construction, verify the location and invert elevation at points of connection of sanitary sewer, storm sewer, water service pipes, and electrical services.

3. Furnish location data for work related to the Project that must be performed by public utilities serving the Project Site.
- C. Verify compatibility with and suitability of substrates, including compatibility with existing finishes or primers.
- D. Examine rough-in for mechanical and electrical systems to verify actual location of connections before equipment and fixture installation.
- E. Examine new and existing facilities for suitable conditions where products and systems are to be installed.

#### 1.5 ACCEPTANCE OF CONDITIONS

- A. Examine substrates, areas, and conditions, with contract personnel present where indicated, for compliance with requirements for installation tolerances and other conditions affecting performance. Record observations.
  1. Written Report: Where a written report listing conditions detrimental to performance of the Work is required by other Sections, include the following:
    - a. Description of the Work
    - b. List of detrimental conditions, including substrates
    - c. List of unacceptable installation tolerances
    - d. Recommended corrections
  2. Verify compatibility with and suitability of substrates, including compatibility with existing finishes or primers.
  3. Examine roughing-in for mechanical and electrical systems to verify actual locations of connections before equipment and fixture installation.
  4. Examine new and existing facilities for suitable conditions where products and systems are to be installed.
- B. Proceed with installation only after unsatisfactory conditions have been corrected.
- C. Proceeding with work indicates acceptance of surfaces and conditions.

PART 2 – PRODUCTS (not used)

PART 3 – EXECUTION (not used)

END OF SECTION

**SECTION 01731  
CUTTING AND PATCHING**

**PART 1 – GENERAL**

**1.1 SUMMARY**

- A. This Section specifies the appropriate methods for performing cutting and patching when installations occur in existing facilities or for improvements including selective demolition, salvaging of materials and equipment, and restoring of pavement and other surfaces and improved areas from damage caused by the Contractor's operations.

**1.2 SUBMITTALS**

- A. Written Request: Submit a written request for approval by the Contracting Officer Representative prior to cutting and patching. A written request is required for any cutting or alteration, which affects:
1. The work of the Authority or any separate contractor,
  2. The structural value or integrity of any element of the Project,
  3. The integrity or effectiveness of weather exposed or moisture-resistant elements or systems,
  4. Building aesthetic qualities for exterior areas or in occupied spaces, or
  5. The efficiency, operation life, maintenance, or safety of operational systems.
- B. Cutting and Patching Proposal: Include in written request the following:
1. Describe the extent of cutting and patching required. Show how it will be performed and indicate why it cannot be avoided.
  2. Describe anticipated results in terms of changes to existing construction. Include changes to structural elements and operating components as well as changes in the building's appearance and other significant visual elements.
  3. List utilities that will be disturbed or affected, including those that will be relocated and those that will be temporarily out-of-service. Indicate how long service will be disrupted.
- C. Structural Elements: Where cutting and patching involves addition of reinforcement to structural elements, submit details and engineering calculations to show how reinforcement is integrated with the original structure to satisfy requirements.
- D. Should conditions of work or schedule indicate change of materials or methods, submit written recommendations to the Contracting Officer Representative, including:
1. Conditions indicating change,
  2. Recommendations for alternative materials or methods, and
  3. Resubmittal as required for substitution.
- E. Approval by the Contracting Officer Representative to proceed with cutting and patching work does not waive the Authority's right to later require complete removal and replacement of any part of the Work found to be unsatisfactory.

### 1.3 QUALITY ASSURANCE

- A. Requirements for Structural Work: Do not cut and patch structural elements in a manner that would change their load carrying capacity or load deflection ratio. Obtain prior approval from the Contracting Officer Representative of the cutting and patching procedures proposed.
- B. Operational Limitations: Do not cut and patch operating elements or related components in a manner that would result in reducing their capacity to perform as intended. Do not cut and patch operating elements or related components in a manner that would result in increased maintenance or decreased operational life or safety. Obtain prior approval from the Contracting Officer Representative of the cutting and patching procedures proposed.
- C. Visual Requirements: Do not cut and patch construction exposed on the exterior or in occupied spaces in a manner that would, in the Contracting Officer Representative's opinion, reduce the building's aesthetic qualities. Do not cut and patch construction in a manner that would result in visual evidence of cutting and patching.
  - 1. If possible, retain the original installer or fabricator to cut and patch exposed Work. If it is impossible to engage the original installer or fabricator, engage another recognized experienced and specialized firm.
  - 2. Remove and replace construction cut and patched in a visually unsatisfactory manner.

### 1.4 EMBEDDED ITEMS

- A. When reinforcing steel, conduit or other items embedded in the concrete are encountered in a drilling or coring operation, the operation shall be stopped and the Contracting Officer Representative immediately notified. Determine whether the embedded item may be cut through and if determined to be permissible, obtain Contracting Officer Representative's concurrence before doing so. If it is not permissible to cut through the embedded item, holes shall be drilled in another location and the original holes patched as directed by Contracting Officer Representative.

### 1.5 PAVEMENT AND IMPROVED AREAS RESTORATION

- A. As applicable, secure permits from the Jurisdictional Authority for all pavement restoration within the limits of said Jurisdictional Authority. Submit Working Drawings of such pavement restoration prepared in accordance with the requirements of the Contract Documents and the Jurisdictional Authority to the Jurisdictional Authority for approval.
- B. During construction operations on this Contract, certain areas currently grassed, landscaped, or otherwise improved may be disturbed or damaged. Restore such areas as specified in Section 00736, PROTECTION OF EXISTING VEGETATION, STRUCTURES, UTILITIES AND IMPROVEMENTS.
- C. Existing surfaces marred or damaged by operations under this Contract shall be repaired or replaced by the Contractor to the condition prior to being marred or damaged as approved by the Contracting Officer Representative.

## PART 2 – PRODUCTS

### 2.1 MATERIALS

- A. General: Use materials identical to existing materials. For exposed surfaces, use materials that visually match existing adjacent surfaces to the fullest extent possible if identical materials are unavailable or cannot be used, use materials whose installed performance will equal or surpass that of existing materials.



## PART 3 – EXECUTION

### 3.1 INSPECTION

- A. Examine surfaces to be cut and patched and conditions under which cutting and patching is to be performed before cutting. If unsafe or unsatisfactory conditions are encountered, take corrective action before proceeding.
- B. After uncovering work, inspect conditions affecting installation of new products.
- C. Report unsatisfactory or questionable conditions to the Contracting Officer Representative in writing, and do not proceed with the Work until the Contracting Officer Representative has provided further instruction.

### 3.2 PREPARATION PRIOR TO CUTTING AND PATCHING

- A. Temporary Support: Provide shoring, bracing, and support as required to maintain structural integrity of the affected portion of the Work.
- B. Protection: Protect existing equipment during cutting and patching to prevent damage. Provide protection from adverse weather conditions for portions of the Project that might be exposed during cutting and patching operations.
- C. Avoid interference with use of adjoining areas or interruption of free passage to adjoining areas.

### 3.3 PERFORMANCE

- A. General: Employ skilled workmen to perform cutting and patching. Proceed with cutting and patching at the earliest feasible time and complete without delay. Cut existing construction to provide for installation of other components or performance of other construction activities and the subsequent patching required to restore surfaces to their original condition.
- B. Cutting: Cut existing construction using methods least likely to damage elements to be retained or elements adjoining construction. Where possible review proposed procedures with the original installer; comply with the original installer's recommendations.
  - 1. In general, where cutting is required, use hand or small power tools designed for sawing or grinding, not hammering and chopping. Cut holes and slots neatly to size required with minimum disturbance of adjacent surfaces. Temporarily cover openings when not in use.
  - 2. To avoid marring existing finished surfaces, cut or drill from the exposed or finished side into concealed surfaces.
  - 3. Cut through concrete and masonry using a cutting machine such as a carborundum saw or diamond core drill.
  - 4. By-pass utility services such as pipe or conduit, before cutting, where services are shown or required to be removed, relocated, or abandoned. Cut off pipe or conduit in walls or partitions to be removed. Cap, valve or plug and seal the remaining portion of pipe or conduit to prevent entrance of moisture or other foreign matter after bypassing and cutting.
- C. Patching: Patch with durable seams that are as invisible as possible. Comply with specified tolerances.
  - 1. Where feasible, inspect and test patched areas to demonstrate integrity of the installation.
  - 2. Restore exposed finishes of patched areas and extend finish restoration into retained adjoining construction in a manner that will eliminate evidence of patching and refinishing.

3. Where removal of walls or partitions extends from one finished area into another, patch and repair floor and wall surfaces in the new space to provide an even surface of uniform color and appearance. Remove existing floor and wall coverings and replace with new materials, if necessary to achieve uniform color and appearance.
4. Where patching occurs within a smooth painted surface, apply a primer and second coat over the patched area and extend the final coat over the entire unbroken area containing the patch.
5. Patch, repair, or rehang existing ceilings as necessary to provide an even plane surface of uniform appearance.

#### 3.4 CLEANING

- A. General: Thoroughly clean areas and spaces where cutting and patching is performed or used as access. Completely remove paint, mortar, oils, putty and items of similar nature. Thoroughly clean piping, conduit and similar features before painting or other finishing is applied. Restore damaged pipe covering to its original condition.

END OF SECTION

**SECTION 01740**  
**CLEANING**

PART 1 – GENERAL

1.1 SUMMARY

- A. This Section includes specifications for furnishing all labor, materials, equipment, and services, and performing all operations necessary for, and properly incidental to, cleanup during construction and final cleaning of the facilities and site prior to Acceptance by the Authority.

1.2 RELATED SECTIONS

- A. Division 16 Electrical, for conduit cleaning.

PART 2 – PRODUCTS (not used)

PART 3 – EXECUTION

3.1 CLEANUP DURING CONSTRUCTION

- A. Keep the entire Site in a neat and orderly condition at all times during construction. Conduct a general cleanup of the Site daily as a part of the Work. Provide general daily cleanup and disposal service for removal of waste and rubbish from the jobsite. Clean material as necessary prior to incorporating into the Work.
- B. Dispose and recycle waste, trash, and debris in a safe, acceptable manner, in accordance with applicable laws and ordinances and as prescribed by Jurisdictional Authorities. Do not bury waste material and debris on the Site. Burning of trash and debris on the Site is prohibited.
- C. Provide daily litter pickup within Project limits. Provide adequate number of trash receptacles for worker's lunches, cigarette butts, and other miscellaneous garbage.

3.2 FINAL CLEANING OF FACILITIES

- A. Prior to final inspection by the Contracting Officer Representative, and after all construction work is essentially complete, thoroughly clean facilities utilizing professional facility cleaners.
- B. Items to be cleaned include, but are not limited to, all glass, doors, opening frames, grilles, trim, exposed non-ferrous metal surfaces, floor coverings, light fixtures and plates, plumbing fixtures and trim, and all finish surfaces throughout the construction.
- C. Vacuum-clean where appropriate and remove all spots, smears, dust, debris, hand prints, and defacements of every sort, including those of vandals. Use commercial cleaning compounds where necessary.
- D. Follow the recommendations of the manufacturers of the materials and items to be cleaned for all cleaning, polishing, and treatment such as waxing or sealing.
- E. Final cleaning shall be in accordance with the project's LEED objectives.

3.3 FINAL SITE CLEANUP

- A. Prior to final inspection, thoroughly clean the entire Site so it is in a neat, acceptable condition. Remove from the entire Site all construction equipment and facilities, construction waste and unused materials, dunnage, loose rock and stones, excess earth, and debris of any description resulting from the Work.

- B. Hose down and scrub clean where necessary all pavement and paved walks.
- C. Thoroughly remove mortar droppings from concrete slabs and pavement. Hose down and scrub clean all concrete flatwork and exposed vertical surfaces of concrete and masonry. Clean all rail surfaces, special trackwork, track drains, handholes, and manholes.
- D. All drainage systems shall be free and clear. All drainage systems and sewers shall be pressure cleaned and inspected, and all catch basins and sumps shall be cleaned.
- E. All conduits shall be cleaned and openings protected.
- F. All spare material shall be delivered to the Authority.

END OF SECTION

**SECTION 01775**  
**CLOSEOUT**

PART 1 – GENERAL

1.1 SUMMARY

- A. This Section includes specifications for performing all operations necessary for and incidental to closing out a Contract and assisting in the Authority's final inspection.
- B. This Section includes procedures for closeout submittals including the following:
  - 1. Operation and maintenance manuals;
  - 2. As-Built Drawings and Specifications;
  - 3. Spare parts list, delivery information, and distribution of spare parts;
  - 4. Training manuals, lesson plans, and student's training manuals and electronic media of such, as applicable;
  - 5. Survey record log;
  - 6. Correspondence file;
  - 7. Releases;
  - 8. Vouchers;
  - 9. Records for design (if provided by Contractor), inspection, testing and other quality elements;
  - 10. Request for final payment;
  - 11. Certifications, affidavits, and warranties and guarantees; and
  - 12. Correction of deficiencies submittals as applicable
- C. This Section establishes required actions by the Contractor for facility systems and subsystems commissioning that include the preparation of an asset database, the preparation of preventive maintenance instructions, and labeling and packaging of spare parts.

1.2 CLOSEOUT SCHEDULE AND PROCEDURE

- A. Changes from Original Conditions:
  - 1. Upon completion of the Work and prior to Substantial Completion, the Contractor shall examine each property to determine changes from the original conditions established by the preconstruction inspection, and Section 01711, ACCEPTANCE OF CONDITIONS, and shall furnish a written description to the Contracting Officer Representative of measures taken to correct damage that may have resulted from performance of this Contract, and shall obtain a written release from each owner accepting condition of the building or structure, corrections, or both, thereby relinquishing any claim against the Contractor. In the event any owner refuses to furnish a release of claims, the Contractor shall notify the Contracting Officer Representative in writing.
  - 2. The Authority will not assume responsibility for alleged damages arising from the Work performed under this Contract.

B. Requirements Preparatory to Final Inspection by the Authority:

1. Notify the Contracting Officer Representative to perform a preliminary final inspection for the purpose of determining the state of completion of the Work. Notify the Contracting Officer Representative at least 14 Days in advance of requested inspection. The Contracting Officer Representative will perform the inspection within 3 working days of the requested date. From the information gathered from this inspection, the Contracting Officer Representative will prepare a Punch List of work to be performed, corrected, or completed before the Work will be accepted. All work on the Punch List shall be completed by the Contractor prior to final inspection.
2. Temporary facilities, except as may be required during Punch List work, shall be removed from the Site.
3. Clean the Site and all applicable appurtenances and improvements as specified in Section 01740, CLEANING.
4. Properly mount operating instructions for equipment and post as specified or required.

C. Final Inspection by the Authority:

1. After all requirements preparatory to the final inspection have been completed as hereinbefore specified, notify the Contracting Officer Representative to perform the final inspection. Notice shall be given at least 14 Days in advance of the time the Work will be available for final inspection. The Contracting Officer Representative will perform the inspection within 3 working days of the requested date.
2. Contractor or its principal superintendent, authorized to act on behalf of the Contractor, shall accompany the Contracting Officer Representative on the final inspection, as well as any principal Subcontractors that the Contracting Officer Representative may request to be present.
3. If the Work has been completed in accordance with the Contract Documents, and no further corrective measures are required, the Contracting Officer Representative will accept the Work and will issue a Certificate of Completion as evidence of acceptance.
4. If the Work has been substantially completed in accordance with the Contract Documents, and the Work can be used for its intended purpose with only minor corrective measures required, the Contracting Officer Representative will conditionally accept the Work and will issue a Certificate of Substantial Completion based upon the Contractor's assurance that corrective measures will be completed within the shortest practicable time. A fixed schedule for such corrective measures shall be submitted to the Contracting Officer Representative for approval.
5. If the Work has not been substantially completed in accordance with the Contract Documents, and several or many corrective measures are still required, the Contracting Officer Representative will not issue a Certificate of Substantial Completion. Instead, a new Punch List will be prepared based on the information gathered from the final inspection, and the Contractor will be required to complete this work and then call for another final inspection, following the procedure outlined above.

D. Asset Database:

1. Prepare a database listing each system and subsystem asset with attribute data to include asset name, asset location, manufacturer name and contact information, model number, serial number, expected useful life, warranty period with start and end date, digital link to warranty documentation, digital link to Operation and Maintenance Manual, spare parts provided for the asset, and special tools required to perform asset maintenance.
2. Sample asset tables are attached at the end of this Section for the Contractor's guidance in preparing the asset database.
3. Databases shall provide asset and parts information for the following equipment:
  - a. Mechanical equipment

E. Preventive Maintenance Instructions:

1. Prepare preventive maintenance instructions for each asset, including asset name, asset location, manufacturer name, model number, serial number, maintenance instructions for each asset and each scheduled maintenance based on requirements of the associated Operations and Maintenance Manual, and identification of special test equipment required to test the asset subsequent to performing maintenance.
2. A sample preventive maintenance instruction is attached at the end of this Section for the Contractor's guidance in preparing the preventive maintenance instructions.

1.3 SUBMITTALS

- A. Make all submittals in accordance with Section 01330, SUBMITTAL PROCEDURES, and as specified below.
- B. Operation and Maintenance:
  1. Furnish manuals for equipment and systems as required by the Contract Documents.
  2. Furnish all completed Operation and Maintenance related materials and training in the specified time relative to installation schedule.
  3. Data copy included from standard catalogs shall be edited to reflect only conditions pertinent to this Contract.
  4. Data copy shall be suitable for dry-copy reproduction on standard office copy machines.
  5. Hard copy manuals shall be prepared using the following materials:
    - a. Binder:
      - (1) One of following:
        - (a) Loose-leaf; three-ring with elliptical rings; stiff cover with covering resistant to oil, water, and wear; reinforced hinges; label holder on spine; mechanical device to open, close and lock rings; and sheet lifters. Size for 8-1/2-inch by 11-inch paper, 3-inch maximum capacity.
        - (b) Loose-leaf three-post binder conforming to FS UU-B-320, Type II, Class 2, with covering resistant to oil, water, and wear; label holder on spine; size for 8-1/2-inch by 11-inch paper; capacity as required, 4-inch maximum thickness.

- (2) When the assembled data exceeds the capacity of one binder, provide additional binders as necessary.
- b. Pages:
  - (1) Originals: White, 60-pound bond with plastic-reinforced binding edge.
  - (2) Catalog data: Offset-printed copy on white paper, with plastic-reinforced edge.
  - (3) Standard: 8-1/2 inches by 11 inches.
  - (4) Fold-out: 11 inches by 8-1/2 inches for binding portion of page plus 7-1/2 inches for each additional portion of folded page; title and page number visible without unfolding. Provide a filler at the binding edge of fold-out pages, equal in thickness to the folded portion.
  - (5) Holes punched for standard three-ring binder.
  - (6) Consecutively numbered.
6. Electronic Copies shall accompany the paper copies of all submittals of all manuals. These electronic copies shall be submitted in an editable, non-copyrighted Microsoft Office format. There shall be two electronic copies per submitted manual delivered one each to the programs office and to the applicable training department.
7. Manuals shall include the following data:
  - a. Table of contents.
  - b. Contractor's name, address and telephone number, with similar data for its 24-hour service organization.
  - c. Manufacturer's name, address and telephone number, with similar data for its local representative, distributor, and service agency.
  - d. Catalog, model, and serial number of equipment installed. Include WMATA unit numbers where applicable.
  - e. Description of equipment.
  - f. Detailed Theory of Operation of each system and subsystem to Lowest Repairable Unit (LRU)
  - g. Troubleshooting and Diagnostic Procedures for each piece of equipment delivered to LRU
  - h. Block Diagrams and Schematics of equipment as installed
  - i. Software administrative procedures for data input, failure diagnosis and system restoration
  - j. Statement of warranty as specified.
  - k. Description of modification, servicing and repairs performed prior to start of warranty.
  - l. Dates warranty begins and expires.
  - m. Standard starting, stopping and operating procedures.
  - n. Emergency and special operating procedures.



- o. Routine maintenance procedures.
  - p. Servicing and lubrication schedule.
  - q. Manufacturer's printed operating and maintenance instructions, manufacturer's parts list, illustrations, and diagrams.
  - r. One copy of each wiring diagram.
  - s. List of spare parts, prices and recommended stock quantities for routine maintenance of the equipment for 1 year and list of spare parts that are considered critical and for which extended time frames for acquisition would create undesirable down-time for equipment.
  - t. List of special tools required to perform inspection, adjustment, maintenance, and repair. Special tools are those developed to perform a unique function related to the particular equipment and not available from commercial sources.
  - u. Copy of each approved Shop Drawing of equipment and system. Include drawings, which show outline dimensions, weights, and assembly data. Do not include drawings, which show manufacturing details.
8. Manuals submittal schedule:
- a. Four copies of sample formats and outlines of contents in draft form 120 Days prior to the time scheduled for operation inspection, testing, or acceptance of the equipment.
  - b. Four copies of complete manual in final form 45 Days prior to the time scheduled for operation inspection, testing, or acceptance of the equipment.
  - c. Four bound sets and electronic media of approved manual before the time scheduled for operation inspection, testing, or acceptance of the equipment.
    - (1) Electronic copy files shall be in latest version of Adobe (.PDF) file format. Files shall be submitted in accordance with Section 01330, SUBMITTAL PROCEDURES.
    - (2) Shop Drawings submitted with manuals shall be in AutoCAD (.DWG) file format. Line work shall be shown on designated layers in accordance with standard CAD layering guidelines as specified in the WMATA CAD Manual. Images shall be clear, sharp, and readily legible.
    - (3) The Authority reserves the right to have any images, illustrations, diagrams, and drawings resubmitted until the Contracting Officer Representative approves their legibility.
  - d. In addition to the other requirements of this Section, if manufacturer's hardcopy illustrations, diagrams, and drawings are also used in the preparation of Operation and Maintenance manual illustrations, diagrams, and drawings, they shall also be furnished in Adobe (.PDF) file formats.
9. If operation and maintenance training is included in the Contract, provide to each trainee, hard and electronic copies of approved operation and maintenance manuals for this purpose as specified in Section 01820, DEMONSTRATION AND TRAINING.

C. As-Built Drawings and Specifications:

- 1. General:
  - a. As-Built Drawings shall include Shop Drawings, Working Drawings, and field prepared drawings.

- b. Maintain a hard copy drawing and specification record of as-built conditions on a set of Contract Documents as the Work progresses. The Contract Documents shall be kept current with all Modifications issued by the Authority. The hard copy drawing and specification record shall be maintained at the Contractor's field office. Periodic review of the completeness of the hard copy record will be conducted by the Authority as deemed necessary to ensure the record is kept up to date.
2. As-Built Drawings:
- a. Draft Deliverable: Submit to the Authority, for review and comment, separate sets of draft As-Built Drawings in both an AutoCAD (.DWG) file format and an Adobe (.PDF) file format (.PDF files shall be capable of printing full-size drawings.), in print quality black and white, with all fonts embedded. The latest versions of both file formats shall be used. All line work shall be shown in accordance with the WMATA CAD Manual. Images shall be clear, sharp, and readily legible. The Authority reserves the right to have drawing(s) resubmitted until the Contracting Officer Representative accepts the legibility of the drawing contained in the file. In addition, submit one set of full-size and two sets of half-size black ink on white paper copies of draft As-Built Drawings for review and comment by the Authority in accordance with Section 01330, SUBMITTAL PROCEDURES.
  - b. Upon return of one set of full-size black ink on white paper copy of the draft As-Built Drawings with Authority comments, incorporate additions and corrections resulting from Authority review comments. Contractor shall direct specific attention, by annotation on resubmitted As-Built Drawings, to revisions other than the corrections requested by the Contracting Officer Representative on previous submittals.
  - c. Final Deliverable: By the date scheduled for receipt of final approved As-Built Drawing deliverables in the Contract Schedule, separate sets of As-Built Drawings in both an AutoCAD (.DWG) file format and an Adobe (.PDF) file format, in print quality black and white, with all fonts embedded. Submit one set of full-size and two sets of half-size black ink on white paper copies, produced from the Adobe file, to the Contracting Officer Representative for review and Approval. If this submittal is found to be incomplete it will be returned to the Contractor with comments for re-submittal.
  - d. The completed As-Built Drawings do not require the signature of the Engineer or Architect of Record. Each completed As-Built Drawing produced in Adobe (.PDF) electronic format shall have the signature of an officer of the Contractor's organization, certifying compliance with as-built conditions, using a stamp as follows:

AS-BUILT

I CERTIFY THAT THIS DRAWING  
ACCURATELY DEPICTS THE WORK  
CONSTRUCTED AS OF

\_\_\_\_\_  
(date)

\_\_\_\_\_  
(an officer of the Contractor)

\_\_\_\_\_  
Contractor's Name

3. As-Built Specifications:
- a. By the date scheduled for receipt of final approved As-Built Specification deliverables in the Contract Schedule, submit As-Built Specifications in both latest version of MSWord

(.DOCX) file format with tracked changes and an Adobe (.PDF) file format, in print quality black and white. Submit two bound sets of black ink on white paper copies produced from the Adobe (.PDF) format to the Contracting Officer Representative for review and acceptance in accordance with Section 01330, SUBMITTAL PROCEDURES.

D. As-Built Project Schedule:

1. Submit one electronic copy of the approved As-Built Project Schedule as required.

E. Spare Parts:

1. This Contract includes the requirement for spare parts, either specifically identified in the price schedule or to be identified later during the term of the Contract. Ensure that all spare parts required by this Contract are provided and delivered in accordance with the following paragraphs.
2. Submit to the Authority the one electronic copy of the list of required spare parts either specifically identified in the unit price schedule or later identified by the Authority in accordance with the Issued for Construction Specifications. The list provided by the Contractor shall include part name, model number, part number, serial number, stock number, component name, location for use, manufacturer's name and contact information, unit cost, quantity, available packaging, special storage and handling instructions, replacement schedule, and anticipated annual usage. In addition, the spare parts listing shall include the following additional information as appropriate:
  - a. Group the list by system and subsystem for inventory system identification. Include order and procurement information for subassemblies and components.
  - b. Correlate the required quantities with the reliability requirements and lead time considering the following classifications:
    - (1) Wear: Components which may be expected to require regular replacement under normal maintenance schedule and operations, such as mechanical parts subject to continuous operation within projected mean time between failure levels.
    - (2) Consumables or expendables: Components which are consumed, used up, destroyed, or upon failure, are otherwise made unusable for their intended purpose and are economically unrecoverable except for inherent scrap value.
    - (3) Recoverable or repairable: Components, which upon failure are capable of being repaired or remanufactured to a serviceable, operational condition and maintained available for use within their initial intended purpose. Such items shall be accounted for via appropriate asset records.
    - (4) Long lead: Components, which are not available on short notice from commercial distributors or within 48 hours from the manufacturer, such as specially made or selected components.
    - (5) Cross referencing: Where replacement components are common to more than one system or subsystem, include a cross reference and indexing system in the replacement components list.
    - (6) Non-unique parts: In all components lists, items which are not unique to the system and have been manufactured by others shall be identified by the manufacturer's name and part number, as well as by the Contractor's component number, if any.
3. Within 30 Days after the Contractor submits the required spare parts listing, the Authority will provide the Contractor with shipping instructions and with WMATA stock numbers for each

item the Contractor is required to furnish. Spare parts shall be packaged such that parts for a particular asset or a particular facility are grouped together. The Contractor shall ship, within a 25-mile radius of the Project, the required parts to the designated points specified by the Authority and shall include the Contract number, manufacturer part number, quantity, unit price, and WMATA part number on the shipping document.

4. The identification of the individual manufacturer's part numbers shall be cross referenced to the assigned WMATA stock numbers by including a column with appropriate heading adjacent to the manufacturer's part numbers in any parts manual or listing provided in accordance with Article 1.03E.2 above.
  5. Parts furnished in accordance with this provision shall not be used to satisfy replacement needs under any warranty provision of this Contract.
  6. Spare parts shall be the same in all respects as their counterparts furnished as part of the assembled equipment to be delivered under the terms of this Contract.
  7. Unless otherwise specified in this Contract, the spare parts shall be delivered at the same time as the counterpart equipment delivery. The spare parts shall be properly packaged or crated so as to prevent damage during shipment and long-term storage. The spare parts shall be labeled in accordance with the instructions contained in Article 1.03E.3 above.
- F. Asset Database as described above.
- G. Preventive Maintenance Instructions as described above.
- H. Survey Field Notes in accordance with Section 01330, SUBMITTAL PROCEDURES:
1. As applicable, submit electronic media of the following as specified in Section 01721, LAYOUT OF WORK AND FIELD ENGINEERING:
    - a. Survey Record Log.
- I. Releases and Vouchers:
1. As applicable, submit one original hard copy and electronic media, in Adobe (.PDF) file format, of releases and vouchers.
- J. Records for Inspection, Testing, and Other Quality Elements:
1. Submit one original hard copy and electronic media, in Adobe (.PDF) file format, of records for inspection, testing or other quality elements as more fully specified in Section 01470, QUALITY MANAGEMENT SYSTEM.
- K. Request for Final Payment:
1. Submit one original hard copy and electronic media, in Adobe (.PDF) file format, of final payment request. Final Settlement will be made in accordance with Section 00744, METHOD OF PAYMENT.

L. Correction of Deficiencies Submittals:

1. As applicable, submit original hard copy and electronic media, in Adobe (.PDF) file format, of Schedule of Deficiency Corrections, Recommendation for Corrective Actions, together with supporting information, Data and Reports applicable to any correction, and a Technical and Cost Proposal to amend the Contract to permit acceptance of the affected materials, equipment, systems, or subsystems as specified in Section 00758, CORRECTION OF DEFICIENCIES.

M. Certifications, Affidavits, and Warranties and Guarantees:

1. Required Affidavits, Certificates, Written Descriptions and Releases and Warranties and Guarantees provided by the Contractor; i.e., Certificates of Acceptance and Compliance, Certification that all facilities were constructed in conformance with ADAAG regulations (Form attached at end of Section), of System Safety and Security, of Substantial Completion, and of Final Payment; Written Description of measures taken to correct damage that may have resulted from performance of this Contract; Written Releases; Contractor's executed Affidavit of Payment of All Applicable Taxes and License Fees in connection with the Contract and Affidavit of Payment of Debts and Claims; Consent of Surety Company to Final Payment; Warranties and Guarantees as specified in Section 00757, WARRANTY/GUARANTEE OF CONSTRUCTION, and Section 00758, CORRECTION OF DEFICIENCIES, and various Sections of the Contract Specifications as applicable: Submit the original hard copy and one electronic copy in Adobe (.PDF) file format.

PART 2 – PRODUCTS (not used)

PART 3 – EXECUTION (not used)

END OF SECTION



**SECTION 01820**  
**DEMONSTRATION AND TRAINING**

**PART 1 – GENERAL**

**1.1 SUMMARY**

- A. This Section includes the general requirements for operation and maintenance training for equipment and systems provided by the Contractor and the general requirements for a Project performance demonstration.
- B. Training shall be conducted in accordance with the following:
  - 1. Operations and Maintenance (O&M) Training: for preventive maintenance instructions (PMI) and corrective maintenance and adjustment of all equipment in its anticipated installed environment.
  - 2. Engineering and Test Technician Training: for performing reliability-oriented inspection, maintenance, diagnostic tests, calibration, troubleshooting and repair of equipment in accordance with applicable standards, and applicable test procedures.

**1.2 DEFINITIONS**

- A. Acronyms used in this specification have the following definitions:
  - 1. TSMT – Technical Skills and Maintenance Training
  - 2. ROQT – Rail Operations Quality Training
  - 3. TTDC – Technical Training Document Control

**1.3 SUBMITTALS**

- A. Submit in accordance with Section 01330, SUBMITTAL PROCEDURES, the following at the times stated:
  - 1. Training plan preliminary submittal: One electronic copy and one printed paper copy not later than 60 Days after commencement of construction work. Submittal shall include at a minimum:
    - a. Instructional outline: A complete, accurate, and detailed listing of topics to be addressed in the instructional program using the specified content list.
    - b. Specimens of instructional material to be used
    - c. Descriptions of audio-visual material and equipment to be used
  - 2. Training plan intermediate submittal: One electronic copy and one printed paper copy not later than 60 Days after approval of preliminary submittal.
    - a. All material submitted for preliminary submittal incorporating or resolving comments.
    - b. Complete instructional plans including audio-visual aids and descriptions of instructional techniques and procedures.
  - 3. Training plan final submittal: One electronic copy and one printed paper copy not later than 30 Days prior to scheduled date for operation inspection, testing, or acceptance of the equipment.

- a. All material submitted for intermediate submittal incorporating or resolving comments.
4. Training contract closeout submittal: As specified in Section 01775, CLOSEOUT.
5. Training instructor's qualifications.
6. A complete set of all training manuals, handouts, aides and presentations, for instructor and student, shall be provided at the end of the vendor's first training class to each of the audience's training groups (two sets when there are two supporting training groups, etc.) in an approved, editable electronic format, and free from copyright restrictions.
7. Printed copies of each student guide and student-learning materials (schematics, books of plans, etc., as determined useful) shall be prepared and bound by equipment's training provider. Provide one printed copy for each student to use during training and to keep after class completion
8. Printed copies of the instructor's guide, student guide, presentation, and all supplemental training materials for each of the audience group's training instructors (not to exceed five copies), free from copyright restrictions, shall be provided at the end of the first vendor training session.
9. Performance demonstration plan and procedures: submit for Approval as part of the final design review package but no later than 90 Days prior to first performance demonstration.

#### 1.4 OPERATION AND MAINTENANCE TRAINING

##### A. General:

1. Where specified, develop and conduct a program to train selected Authority personnel in the operation and maintenance of equipment and systems furnished.
2. Furnish instructors, instructional materials, and audio-visual aids and equipment.
3. The Authority will furnish physical facilities.

##### B. Operations training:

1. Operations training shall be tailored specifically to the WMATA equipment being purchased and training shall be designed to teach all trainees the functional use of all of the major modes of equipment operation.
2. The training shall be sufficient in quality and scope to bring personnel to a level of operating proficiency such that vendor support is not needed during routine equipment operation in any mode or capacity.

##### C. Maintenance training:

1. Maintenance training shall be tailored specifically to the WMATA equipment being purchased and shall be designed to develop the knowledge and skills required to maintain and repair all item(s) delivered under the Contract. Maintenance training shall address the detailed theory of operation, maintenance, testing, repair, overhaul, replacement, alignment, and troubleshooting of the delivered equipment (hardware and software).

##### D. Other Training:

1. Any other training (as determined by WMATA) necessary to support the safe operation, use, or maintenance of the equipment.

##### E. Training Plan:



1. Training plan shall contain an organized summary of the events, and associated times, necessary for the completion of all materials necessary to successfully perform the required training. The plan shall be submitted to the applicable end user's training group(s) (TTDC, TSMT, or ROQT currently) within a Contract specified period after NTP has been issued. The training plan must address all deliverables using a timeline that includes periods for review, feedback, resubmission, approval, and delivery accomplishing all by a Contract-determined date related to the equipment being placed into service. The training plan shall include the following:
  - a. Course list including course title, duration, audience, audience size, and purpose
  - b. Course outline: A course outline with measurable learning objectives shall be provided. The course outline shall provide a topic outline for each item of equipment. Maintenance training shall include a section devoted to system fault analysis and trouble-shooting. The learning objectives shall be stated for each topic.
  - c. Lesson plans: A set of lesson plans shall be developed for each item of equipment corresponding to the topic outline and shall contain the following information: Lesson title, instruction time, objectives, training aids required, instructing sequence (outline), tests, and summary.
  - d. Instructor qualifications: A description of the instructor's qualifications for each class must be submitted to the end user's training group(s) (TTDC, TSMT, or ROQT currently) for approval as part of the training plan. The description (resumé, curriculum vitae, or other description of instructional qualifications) shall document a thorough knowledge of the subject equipment, an understanding of the adult learning process, and demonstrated experience in vocational instruction.
  - e. Audience qualifications and prerequisites: For the purpose of course development and presentation, vendors shall assume all WMATA students are high school graduates (or equivalent)
  - f. Instruction and testing methods to be utilized
  - g. Summary of the strategies to be employed in the accomplishment of the training
  - h. Proposed schedule of delivery of materials and training

F. Instructor's Guide:

1. The instructor's guide for each course shall contain all the information and direction necessary for the instructor to make an effective presentation. The instructor's guides shall include adequate guidelines to conduct a comprehensive training program. Individual lessons within the course shall be organized as separate blocks (or modules), which may be taught as a unit. In some instances, the same standard operating procedures could be used for train operators, transportation supervisors, and central control supervisors. The instructor's guide shall contain, at a minimum:
  - a. Program overview stating the overall program goals
  - b. Training syllabus
  - c. Lesson plans arranged as a session by session outline containing the following:
    - (1) Overview of each lesson
    - (2) Outline of major topics to be covered including timelines for each course, lesson, and topic

- (3) Outline of learning objectives for each major topic
  - (4) Information regarding important subjects and terms to be emphasized during each section of the training
  - (5) References to the associated Student Guide pages and presentation slides
  - d. Suggested instructional methods/learning activities
  - e. Required equipment or resources needed for effective instruction
  - f. Test question pool(s) with each question referenced to the respective learning objective(s) and student guide or other instructional materials
2. A guide (FAQ) providing questions/problems and answers as related to course content
- G. Student's Guides:
1. Student guides for each course that shall contain all the information and direction necessary the student to interact effectively in the learning environment. The student guides shall be written in a fully developed prose format, developed in the same modular format as the instructor's guides. The student's guides should contain, at a minimum:
    - a. Program overview/introduction
    - b. Statement of overall program goals
    - c. All major topics to be covered
    - d. Student learning objectives associated with each of the major topics stated in quantifiable terms
    - e. All illustrations, block diagrams, charts, schematics, wiring diagrams, logic flow diagrams, troubleshooting guides, graphics, and visual aids that may be used during course presentation to enhance presentation content and provide a seamless facilitation of instruction
    - f. Supplemental materials that may be necessary to facilitate theoretical discussions
- H. Training Presentations:
1. Training Presentations shall be matched to the instructor guides and student guides and shall facilitate seamless, effective communication of the course information to the target audience.
  2. Training Presentation format(s) shall be agreed upon by the target audience's training group(s) (TTDC, TSMT, ROQT, currently).
  3. Power Point presentations: Power Point Presentation will be made for equipment designed to follow the curriculum as outlined in the Instructors Guide.
- I. Training Aides:
1. Depending upon the equipment or system(s), a functional mockup or a functional representation may be required. These may be in the form of animated illustrations, animated schematics, interactive video training, or any accepted media format as determined by the audience's training group.
  2. All mockups become the property of audience's training group after completion of the final scheduled training class. Supplemental materials shall be demonstrated as fully operable

during the first training class. All necessary repairs to the supplemental materials are the responsibility of the vendor for the duration of vendor training sessions.

3. Installed equipment shall be used in the course of instruction.
  4. Training shall include practical exercises that permit the trainees to perform hands-on work using installed equipment under normal operating conditions.
- J. OEM Operator's Manual(s) describing the equipment's or system's operation in each mode and capacity of use.
1. OEM Technical Manuals describing the detailed theory of operation, maintenance, testing, repair, overhaul, replacement, alignment, and troubleshooting shall be delivered to the appropriate training groups.

#### 1.5 MATERIALS AND INSTRUCTION

- A. Training materials shall be provided and approved by audience's training groups (TTDC, TSMT or ROQT) prior to the final acceptance of training schedule or training date(s).
- B. Training materials updates are required when, in the scope of the Contract, changes or Modifications are made that affect the operation or maintenance of the contracted item(s).
- C. Instruction shall include material covered in the operation and maintenance manuals as well as the following:
1. Detailed theory of operation to one level below Lowest Repairable Unit (LRU)
  2. Practical aspects of operation
  3. Description of system, equipment, and components
  4. Functional characteristics of system, equipment, and components
  5. Emergency operating procedures
  6. Location, removal, and reinstallation of components
  7. Maintenance procedures
  8. Servicing intervals and schedules
  9. Block diagrams of equipment hardware and software functionality as installed
  10. Schematics of equipment hardware as installed
  11. Diagnosis and problem solving (troubleshooting)
  12. Repair
  13. Overhaul
- D. Daily class duration shall be a nominal 7-1/2-hour shift, with advantageous combinations of theoretical/classroom instruction and hands-on practice, utilizing operational equipment, presentations, mockups, and test equipment as applicable. For on-the-job training (OJT) at work locations as applicable, training shall include participation in installation activities, fault diagnosis, and equipment alignment/adjustment exercises.
1. Location: The WMATA shall provide training facility.

2. Times: Class times will be at convenience of the Authority.
- E. Operating and maintenance training shall be completed prior to the time scheduled for operation inspection, testing, or acceptance of the equipment. In addition to the retainage specified in Section 00744, METHOD OF PAYMENT, payment will be withheld until training is complete and accepted.
- F. Furnish to applicable training group, a minimum of four O&M Manuals as described in Section 01775, CLOSEOUT, for each piece of equipment and system, unless otherwise specified, and a minimum of one editable, non-copyrighted electronic copy in a Microsoft Office format, as specified.
- G. The Authority shall be permitted to videotape all class presentation.
- H. The Authority shall have right to reproduce and unlimited copies of all training materials presented as required for the Authority's instruction needs.
- I. Instruction shall include an evaluation device(s) designed to measure the extent to which students have met the learning objectives.

#### 1.6 PROJECT PERFORMANCE DEMONSTRATION

- A. Integrated system testing shall culminate in a project performance demonstration that shall simulate all operations and shall exercise all systems and system elements. Prepare performance demonstration plan and procedures. Include testing of anticipated normal and abnormal operations, in addition to simulations of emergency operations. Performance demonstration plan shall delineate the following:
  1. Tests to be performed
  2. Date and time when each test is to be performed
  3. An outline of the test parameters
  4. Pass/fail criteria, which must be quantified and measurable
- B. The project performance demonstration shall include those static and dynamic tests used to demonstrate that the Contractor designed the systems and subsystems according to the specification and the performance specified, and shall include:
  1. All necessary functional and performance testing conducted during construction and manufacture of the system elements; and
  2. Operational tests, which include integrated testing of system interfaces to assure that the Project as a whole is capable of operating as specified.

PART 2 – PRODUCTS (not used)

PART 3 – EXECUTION (not used)

END OF SECTION

# **ATTACHMENTS**



# System Safety and Environmental Management Material Safety Data Sheet Review Request

Return this form to Chemical Safety Liaison Officer at Carmen Turner Facility.  
Email to [kbest@wmata.com](mailto:kbest@wmata.com) or Fax to 240-487-3673



**Attach clear copy of current MSDS**

## Please Provide the Following Information

<b>Today's Date:</b>	<b>Requesting Dept.:</b>	<b>Contact Location:</b>
<b>Contact Name:</b>		<b>Phone:</b>
<b>Location(s) where product will be stored:</b>		
<b>Material Status:</b> <i>(check all that apply)</i>	In Use <input type="checkbox"/> New Material <input type="checkbox"/> For Testing <input type="checkbox"/>	
<b>Is this item for contractor use??</b>	<input type="checkbox"/> Yes <input type="checkbox"/> No Contractor Name: _____ Contract No.: _____	
<b>Will this be a Stock or non-stock item?</b>		
<b>Trade Name as shown on MSDS:</b>		
<b>WMATA Stock No.:</b>		
<b>SARP MSDS No.:</b>		
<b>Give name and MSDS number of existing product that this will replace:</b>		
<b>Why is replacement necessary?</b>		
<b>Where will product be used?</b>		
<b>Description of use:</b>		
<b>How will product be applied?</b>		
<b>Size of Container:</b>		
<b>Quantity used per week:</b>		
<b>Physical State of Product:</b>	Aerosol Spray <input type="checkbox"/> Gas <input type="checkbox"/> Liquid <input type="checkbox"/> Paste/Cream <input type="checkbox"/> Pellets <input type="checkbox"/> Powder <input type="checkbox"/> Solid <input type="checkbox"/> Other <input type="checkbox"/> <i>(Please specify)</i>	
<b>Manufacturer's Name, Phone No. &amp; web address:</b>		
<b>Vendor's Name &amp; Phone No.:</b>		
<b>Best Time to Contact You (Requestor):</b>		
<b>Comments:</b>		







Level 3 - Items		Level 2 - Sub-Items		Level 1 - Sub-Item		Level 0 - Item		Safety/Security Certifiable Items Ref Date: 8/21/12			Rev: 2			Design Conformance Checklist			Installation & Construction Conformance Checklist			Testing & Inspection Conformance Checklist			Final Verification			Certifiable Items List Template
Item ID	Item Description	Design Criteria	Doc Ref	Verified By	Company Verified By	Date	Doc Ref	Verified By	Company Verified By	Date	Doc Ref	Verified By	Company Verified By	Date	Doc Ref	Verified By	Company Verified By	Date	Doc Ref	Verified By	Company Verified By	Date	Comments			
1 9 2 1	Aisle Lift	Section 14450	Section 14450	RM	SYSTRA	6/6/11	Submittal Package #0001-14450-1, #0002-144450-2	TCY	HPCC	11/14/11	HPCC SSC Pl. File #80.1.9	J. Hueg	B&R Associates	8/21/12	HPCC SSC Pl. File #80.1.9	MB	HPCC	8/21/12	COMPLETE							
1 9 2 2	Parallelogram Lift	Section 14450	Section 14450	RM	SYSTRA	6/6/11	Submittal Package #0003-14450-2, #0004-14450-2, #0005-14450-2	TCY	HPCC	11/14/11	HPCC SSC Pl. File #80.1.9	J. Hueg	B&R Associates	8/21/12	HPCC SSC Pl. File #80.1.9	MB	HPCC	8/21/12	COMPLETE							
1 10	Lighting Fixtures and Mounting Poles																									
1 10 1	Basic Electrical Materials and Methods	RFP - FQB133 - Electrical Program Requirements - Section II - Basic Electrical	Section 16050 / Dwg #E-002 thru E-601 / NECA-1:2006, 101:2006, NFPA 70, ANS/IEEE C2 NESC	C. Aza	SYSTRA	6/10/11	Submittal Package #0001-16525-0	TCY	HPCC	12/9/11	HPCC SSC Pl. File #80.1.10	C. Aza	Mona Electric Group	8/21/12	HPCC SSC Pl. File #80.1.10	MB	HPCC	8/21/12	COMPLETE							
1 10 2	Grounding and Bonding	RFP - FQB133 - Electrical Program Requirements - Section II - Basic Electrical - Part C	Section 16060 / Dwg #E-002 thru E-601 / NEC Art. 250, ANS/IEEE 80-2000, ASTM B387-00	C. Aza	SYSTRA	6/10/11	Submittal Package #0001-16660-0	TCY	HPCC	12/9/11	HPCC SSC Pl. File #80.1.10	C. Aza	Mona Electric Group	8/21/12	HPCC SSC Pl. File #80.1.10	MB	HPCC	8/21/12	COMPLETE							
1 10 3	Wire, Cable and Busways	RFP - FQB133 - Electrical Program Requirements - Section II - Wire Management	Section 16120 / Dwg #E-002 thru E-601 / NEC	C. Aza	SYSTRA	6/10/11	Submittal Packages #0001-16120-0, #0003-16120-0	TCY	HPCC	12/9/11	HPCC SSC Pl. File #80.1.10	C. Aza	Mona Electric Group	8/21/12	HPCC SSC Pl. File #80.1.10	MB	HPCC	8/21/12	COMPLETE							
1 10 4	Wire Connection Accessories	RFP - FQB133 - Electrical Program Requirements - Section II - Wire Management	Section 16125 / Dwg #E-002 thru E-601 / NEC	C. Aza	SYSTRA	6/10/11	Submittal Packages #0001-16125-1, #0003-16120-0, #0004-16125-0	TCY	HPCC	12/9/11	HPCC SSC Pl. File #80.1.10	C. Aza	Mona Electric Group	8/21/12	HPCC SSC Pl. File #80.1.10	MB	HPCC	8/21/12	COMPLETE							
1 10 5	Raceways, Boxes and Cabinets	RFP - FQB133 - Electrical Program Requirements - Section II - Wire Management - Part B	Section 16130 / Dwg #E-002 thru E-601 / NEC, NEMA 250	C. Aza	SYSTRA	6/10/11	Submittal Packages #0001-16130-1, #0002-16130-0, #0003-16130-0, #0004-16130-0, #0005-16130-0, #0006-16130-0, #0007-16130-0, #0008-16130-0, #0009-16130-0, #0010-16130-0	TCY	HPCC	12/9/11	HPCC SSC Pl. File #80.1.10	C. Aza	Mona Electric Group	8/21/12	HPCC SSC Pl. File #80.1.10	MB	HPCC	8/21/12	COMPLETE							
1 10 6	Lighting Fixtures and Mounting Poles (a2)	RFP - FQB133 - Electrical Program Requirements - Section VII - Lighting - Part D	Section 16525 / Dwg #E-002 thru E-601 / NEC, UL 496, 542, 1029, 1570, 1571, 1572, ASTM A339TD, NAAMM, ANS/IEEE, NEMA, FCC	C. Aza	SYSTRA	6/10/11	Submittal Packages #0004-16525-0	TCY	HPCC	12/9/11	HPCC SSC Pl. File #80.1.10	C. Aza	Mona Electric Group	8/21/12	HPCC SSC Pl. File #80.1.10	MB	HPCC	8/21/12	COMPLETE							
1 10 6 1	Exterior Lighting	RFP - FQB133 - Electrical Program Requirements - Section VII - Lighting - Part D	RFP (Book 2) VII.A.3.b. & 4.c./d / Dwg #E-002 thru E-601	C. Aza	SYSTRA	6/10/11	Submittal Packages #0001-16525-0	TCY	HPCC	12/9/2011	HPCC SSC Pl. File #80.1.10	C. Aza	Mona Electric Group	8/21/12	HPCC SSC Pl. File #80.1.10	MB	HPCC	8/21/12	COMPLETE							
1 11	Overhead Colling Doors																									
1 11 1	Overhead Colling Doors	RFP - FQB133 - Architectural Program Requirements - Section V - Exterior Doors	Section 08331 / Dwg #WA-600 & MA-600 thru MA-603 / ASTM A36, A123, A653, I84, NFPA 70, 80 & UL 108	B. Fishery	SYSTRA	9/13/2011	Submittal Package #0002-08331-2	TCY	SYSTRA	12/29/2011	HPCC SSC Pl. File #80.1.11	David Smith	Just Rite	8/21/12	HPCC SSC Pl. File #80.1.11	MB	HPCC	8/21/12	COMPLETE							
2 0	Operations																									
2 1	Pedestrian Movement																									
2 1 1	Signage	RFP - FQB133 - Site Improvements Program Requirements - Parking Lots	Section 10431 / Dwg #C-501 thru C-504	B. Fishery	SYSTRA		Submittal Package #0001-10431-1, 0002-10431-0	TCY	HPCC	6/18/2012	HPCC SSC Pl. File #80.2.2	Mike Volpicelli	All State Striping	N/A	HPCC SSC Pl. File #80.2.1	MB	HPCC	6/29/12	COMPLETE							
2 1 2	Pavement Marking	RFP - FQB133 - Site Improvements Program Requirements - Parking Lots	Section 10432 / Dwg #C-501 thru C-504	B. Fishery	SYSTRA		Submittal Package #0001-02765-0	TCY	HPCC	6/18/2012	HPCC SSC Pl. File #80.2.2	Mike Volpicelli	All State Striping	N/A	HPCC SSC Pl. File #80.2.1	MB	HPCC	6/29/12	COMPLETE							
2 2	Vehicle Movement																									
2 2 1	Signage	RFP - FQB133 - Site Improvements Program Requirements - Parking Lots	Section 10431 / Dwg #C-501 thru C-504 & WA-102, WA-651	B. Fishery	SYSTRA		Submittal Package #0001-10431-1, 0002-10431-0	TCY	HPCC	6/18/2012	HPCC SSC Pl. File #80.2.3	Mike Volpicelli	All State Striping	N/A	HPCC SSC Pl. File #80.2.2	MB	HPCC	6/29/12	COMPLETE							
2 2 2	Pavement Marking	RFP - FQB133 - Site Improvements Program Requirements - Parking Lots	Section 02765 / Dwg #C-501 thru C-504 & WA-102	B. Fishery	SYSTRA		Submittal Package #0001-02765-0	TCY	HPCC	6/18/2012	HPCC SSC Pl. File #80.2.3	Mike Volpicelli	All State Striping	N/A	HPCC SSC Pl. File #80.2.2	MB	HPCC	6/29/12	COMPLETE							
2 3	Snow Removal																									
2 3 1	Snow Gates	Section 05500	Section 05500	B. Fishery	SYSTRA	5/26/11	Submittal Package #0004-05500-0	TCY	HPCC	6/30/2011	HPCC SSC Pl. File #80.2.3	H. Wright, Jr	Wright's Iron	4/20/12	HPCC SSC Pl. File #80.2.3	MB	HPCC	6/29/12	COMPLETE							
3 0	Communications																									
3 1	Telephone System																									
3 1 1	Telecomm Standard Specifications	TIA/EIA568-B	Section 16700 / Dwg #MT-001 thru MT-617 / FT-001 thru FT-609 / WT-001 thru WT-609	J. Ray	SYSTRA	6/6/11	Submittal Package #0001-16700-0	TCY	HPCC	10/12/11	HPCC SSC Pl. File #80.3.1	C. Aza	Mona Electric Group	N/A	HPCC SSC Pl. File #80.3.1	MB	HPCC	6/29/12	COMPLETE							
3 1 2	Comm System Submittals and Services	Design Build Specifications - Division 16 - 16706 - Communications Systems QA and Testing	Section 16706 / Dwg #MT-001 thru MT-617 / FT-001 thru FT-609 / WT-001 thru WT-609	J. Ray	SYSTRA	6/6/11	N/A	TCY	HPCC	10/12/11	HPCC SSC Pl. File #80.3.1	C. Aza	Mona Electric Group	N/A	HPCC SSC Pl. File #80.3.1	MB	HPCC	6/29/12	COMPLETE							
3 1 3	Comm System QA and Testing	Design Build Specifications - Division 16 - 16707 - Communications Systems QA and Testing	Section 16707 / Dwg #MT-001 thru MT-617 / FT-001 thru FT-609 / WT-001 thru WT-609	J. Ray	SYSTRA	6/6/11	N/A	TCY	HPCC	10/12/11	HPCC SSC Pl. File #80.3.1	C. Aza	Mona Electric Group	N/A	HPCC SSC Pl. File #80.3.1	MB	HPCC	6/29/12	COMPLETE							
3 1 4	Communications Grounding	Design Build Specifications - Division 16 - 16710 - Communications Grounding	Section 16710 / Dwg #MT-001 thru MT-617 / FT-001 thru FT-609 / WT-001 thru WT-609	J. Ray	SYSTRA	6/6/11	Submittal Package #0001-16660-0, #0001-16060-0, #0002-16710-0, #0001-16710-0	TCY	HPCC	10/12/11	HPCC SSC Pl. File #80.3.1	C. Aza	Mona Electric Group	N/A	HPCC SSC Pl. File #80.3.1	MB	HPCC	6/29/12	COMPLETE							
3 1 5	Communications Electrical Power Dist.	Design Build Specifications - Division 16 - 16715 - Communications Electrical Power Distribution	Section 16715 / Dwg #MT-001 thru MT-617 / FT-001 thru FT-609 / WT-001 thru WT-609	J. Ray	SYSTRA	6/6/11	Submittal Package #0001-16715-1, 0004-02585-1, 0005-02585-0, 0006-02585-0, 0001-16715-1	TCY	HPCC	10/12/11	HPCC SSC Pl. File #80.3.1	C. Aza	Mona Electric Group	6/26/12	HPCC SSC Pl. File #80.3.1	MB	HPCC	6/29/12	COMPLETE							
3 1 6	Communications - Telephone System	Design Build Specifications - Division 16 - 16721 - Communications - Telephone and Data System	Section 16721 / Dwg #MT-001 thru MT-617 / FT-001 thru FT-609 / WT-001 thru WT-609	J. Ray	SYSTRA	6/6/11	Submittal Package #0002-02585-0, #0003-02585-0, #0001-16700-0, #0001-16721-0, #0002-16721-0, #0003-16721-0, #0001-16700-0, #0002-16700-0	TCY	HPCC	10/12/11	HPCC SSC Pl. File #80.3.1	C. Aza	Mona Electric Group	N/A	HPCC SSC Pl. File #80.3.1	MB	HPCC	6/29/12	COMPLETE							
3 1 7	Communications - Public Address	RFP - FQB133 - Communications & Security Program Requirements - Part F	Section 16821 / Dwg #MT-001 thru MT-617 / FT-001 thru FT-609 / WT-001 thru WT-609	J. Ray	SYSTRA	6/6/11	Submittal Package #0001-16821-0, #0002-16821-1	TCY	HPCC	5/21/12	HPCC SSC Pl. File #80.3.1	C. Aza	Mona Electric Group	6/26/12	HPCC SSC Pl. File #80.3.1	MB	HPCC	6/29/12	COMPLETE							
3 2	Video Surveillance																									
3 2 1	Video Surveillance	RFP - FQB133 - Communications & Security Program Requirements - Part D	Section 16781 / Dwg #MT-001 thru MT-617 / FT-001 thru FT-609 / WT-001 thru WT-609	J. Ray	SYSTRA	6/6/11	Submittal Package #0001-16781-0	TCY	HPCC	5/21/12	HPCC SSC Pl. File #80.3.2	C. Aza	Mona Electric Group	1/0/00	HPCC SSC Pl. File #80.3.2	MB	HPCC	8/21/12	COMPLETE							

Safety/Security Certifiable Items Ref Date: 8/21/12		Rev: 2	Design Conformance Checklist				Installation & Construction Conformance Checklist				Testing & Inspection Conformance Checklist				Final Verification				Certifiable Items List Template HPCC Concurrence: DSP NMA/TA Concurrence: NOS WMATA/SAFE: RLF					
Level 1 - Items	Level 2 - Sub-Items	Level 3 - Item	Level 4 - Sub-Item	Level 5 - Sub-Item Item	Item Description	Design Criteria	Doc Ref	Verified By	Company Verified By	Date	Doc Ref	Verified By	Company Verified By	Date	Doc Ref	Verified By	Company Verified By	Date	Doc Ref	Verified By	Company Verified By	Date	Comments	
<b>Integrated Systems</b>																								
<b>4 1 UG Electrical and Comms Dist Systems</b>																								
4	1				UG Electrical and Comms Dist Systems	RFP - FQR133 - Electrical Program Requirements - Section VI - Building Service and Distribution - Part A.4	Section 02585 / Dwg #F - 505 & T002 thru T-507 / ASTM A36, A48, A123, A185, A615, C13, C109, C173, C313, D570, D638, D790, F512, NEMA TC 14, RN 1, UL 6	C. Aza	SYSTRA	6/10/11	Submittal #0001-02585-3, 0002-02585-0, 0003-02585-0, 0004-02585-1, 0006-02585-0, 0005-16130-0, 0008-16130-0	TCY	HPCC	12/20/11	HPCC SSC Pl. File #B0.4.1	C. Aza	Mona		8/21/12	HPCC SSC Pl. File #B0.4.1	MB	HPCC	8/21/12	COMPLETE
<b>4 2 Division 13 Equipment</b>																								
4	2	1			Shop Equipment	Design Build Specifications - Division 11 - 11510 - Shop Equipment	Section 11510 / Dwg #MQ-000 thru MQ-601	R. Miller	SYSTRA	6/6/11	Submittal #0001-11510-0, 0001-10670-0, 0004-11510-0, 0008-11510-1, 0001-11515-1, 0002-11515-2	TCY	HPCC		HPCC SSC Pl. File #B0.4.2	J. Hugg	B&R Associates		8/21/12	HPCC SSC Pl. File #B0.4.2	MB	HPCC	8/21/12	COMPLETE
4	2	2			Shop Equipment (Guard Booth)	Design Build Specifications - Division 11 - 11510 - Shop Equipment - Section 2.32	Section 11510 / Submittal #0003-11510-6	G. Morton	SYSTRA	6/6/11	Submittal #0001-11510-6	TCY	HPCC	4/19/12	HPCC SSC Pl. File #B0.4.2	G. Morton	Shelter's Direct		8/21/12	HPCC SSC Pl. File #B0.4.2	MB	HPCC	8/21/12	COMPLETE
4	2	3			Vehicle Wash Equipment	Design Build Specifications - Division 11 - 11550 - Vehicle Wash Equipment	Section 11550 / Dwg #WQ-000 thru WQ-400	R. Miller	SYSTRA	6/6/11	Submittal #0001-11550-0	TCY	HPCC	1/31/12	HPCC SSC Pl. File #B0.4.2	T. Allen	Ross & White		6/8/12	HPCC SSC Pl. File #B0.4.2	MB	HPCC	8/21/12	COMPLETE
<b>4 3 Fire Protection Systems</b>																								
4	3	1			Fire Protection, Suppression and Alarm	RFP - FQR133 - Fire Protection Program Requirements - Section I - Fire Protection System Requirements - I.B.2	Section 13905 / Dwg #TT-102, FT 405 thru FT 406, MT-108 thru MT-112, MT-610 thru MT-612, MP-100 thru MP-300 & WT-103 thru WT-104, WT-605 thru WT-606, WF-100 thru WF-300 / NFPA 13, 14, 20 / UL 262, 312, 1479 / ASTM, ANS/ASME, NEMA 250	M. Romano	SYSTRA	6/9/11	Submittal #0001-13905-0, 0002-13905-0, 0003-13905-1, 0004-13905-0, 0005-13905-0, 0006-13905-0	TCY	HPCC	3/1/12	HPCC SSC Pl. File #B0.4.3	J. Hazard	FLSA		6/12/12	HPCC SSC Pl. File #B0.4.3	MB	HPCC	6/29/12	COMPLETE
4	3	2			Fire Alarm System	RFP - FQR133 - Fire Protection Program Requirements - Section I - Fire Protection System Requirements - I.B.1	Section 16731 / Dwg #TT-102, FT 405 thru FT 406, MT-108 thru MT-112, MT-610 thru MT-612, MP-100 thru MP-300 & WT-103 thru WT-104, WT-605 thru WT-606, WF-100 thru WF-300	M. Romano	SYSTRA	6/9/11	Submittal #0001-16731-1, 0002-16731-0	TCY	HPCC	3/2/12	HPCC SSC Pl. File #B0.4.3	C. Aza	Mona Electric Group		8/21/12	HPCC SSC Pl. File #B0.4.3	MB	HPCC	6/29/12	COMPLETE
<b>4 4 Elevator</b>																								
4	4	1			Hydraulic Passenger Elevator	RFP - FQR133 - Architectural Program Requirements - XVI - Elevator	Section 14200	B. Fitzhenry	SYSTRA	6/6/11	Submittal #0002-14200-2	TCY	HPCC	12/19/11	HPCC SSC Pl. File #B0.4.4.1	D. Daniels	PKD		8/21/12	HPCC SSC Pl. File #B0.4.4	MB	HPCC	8/21/12	COMPLETE
<b>4 5 Heating Hot Water System</b>																								
4	5	1			Vibration Isolation	Design Build Specifications - Division 15 - 15070 - Vibration Isolation	Section 15070 / ASTM A123	S. Murphy	LEDS	6/14/11	Submittal #0002-15135-1	TCY	HPCC	10/18/11	HPCC SSC Pl. File #B0.4.5	K. Guntow	Limbach		6/18/12	HPCC SSC Pl. File #B0.4.5	MB	HPCC	8/21/12	COMPLETE
4	5	2			ID of Mechanical Equip and Piping	Design Build Specifications - Division 15 - 15075	Section 15075 / Dwg #FM-100, MM-100 thru MM-103, WM-100 / ANSI A13.1-1981	S. Murphy	LEDS	6/14/11	Submittal #0002-15135-1	TCY	HPCC	N/A	HPCC SSC Pl. File #B0.4.5	K. Guntow	Limbach		6/18/12	HPCC SSC Pl. File #B0.4.5	MB	HPCC	8/21/12	COMPLETE
4	5	3			Heating Hot Water System & Equipment	Design Build Specifications - Division 15 - 15135, 15205, 15765	Section 15135, 15205, 15765 / Dwg #MM-204 thru MP-404, FP-100 thru FP-400, MP-100 thru MP-400 & WP-100 thru WP-404 / UL 1025, NEMA 250, ASSE, AWWA, ASME	S. Murphy	LEDS	6/14/11	Submittal #0002-15135-1	TCY	HPCC	2/22/12	HPCC SSC Pl. File #B0.4.5	K. Guntow	Limbach		6/18/12	HPCC SSC Pl. File #B0.4.5	MB	HPCC	8/21/12	COMPLETE
<b>4 6 Natural Gas</b>																								
4	6	1			ID of Mechanical Equip and Piping	Design Build Specifications - Division 15 - 15192 - ID of Mechanical Equip and Piping	Section 15192	S. Murphy	LEDS	6/14/11	Submittal #0004-15192-1	TCY	HPCC	11/14/11	HPCC SSC Pl. File #B0.4.6	K. Guntow	Limbach		4/2/12	HPCC SSC Pl. File #B0.4.6	MB	HPCC	6/29/12	COMPLETE
4	6	2			Natural Gas	RFP - FQR133 - Plumbing Program Requirements - Section V - Natural Gas Piping	Section 11510, 11550, 15205 / Dwg #MP-207 thru MP-210	S. Murphy	LEDS	6/14/11	Submittal #0009-15205-1	TCY	HPCC	11/14/11	HPCC SSC Pl. File #B0.4.6	K. Guntow	Limbach		4/2/12	HPCC SSC Pl. File #B0.4.6	MB	HPCC	6/29/12	COMPLETE
<b>4 7 Piping Systems - Above Ground Maintenance &amp; Plumbing</b>																								
4	7	1			Shop Fluid Services Piping - Compressed Air	RFP - FQR133 - Plumbing Program Requirements - Section VI - Compressed Air System - Part E	Section 15206 / Dwg #MQ-000 thru MQ-601, FQ-000 thru FQ-602 / NFPA 30, 31, 70, 77 / DCMR Title 20 / ASME B31.9	S. Murphy	LEDS	6/14/11	Submittal #0001-15206-0	TCY	HPCC	1/25/12	HPCC SSC Pl. File #B0.4.7	K. Guntow	Limbach		8/21/12	HPCC SSC Pl. File #B0.4.7	MB	HPCC	8/21/12	COMPLETE
4	7	2			Shop Fluid Services Piping - Maintenance Fluids	RFP - FQR133 - Plumbing Program Requirements - Section VI - Maintenance Fluid Systems - Part E	Section 15206 / Dwg #MQ-000 thru MQ-601, FQ-000 thru FQ-602 / NFPA 30, 31, 70, 77 / DCMR Title 20 / ASME B31.9	S. Murphy	LEDS	6/14/11	Submittal #0002-15206-1	TCY	HPCC	1/16/12	HPCC SSC Pl. File #B0.4.7	B. Dorsey	Jones & Frank		8/21/12	HPCC SSC Pl. File #B0.4.7	MB	HPCC	8/21/12	COMPLETE
<b>4 8 Ventilation and A/C Systems</b>																								
4	8	1			Ventilating Units and Heating Equipment and Ductwork	RFP - FQR133 - HVAC Program Requirements - Section I - HVAC Program Requirements - Parts B & C	Sections 15563, 15726, 15732, 15735, 15765 & 15810	S. Murphy	LEDS	6/14/11	Submittal #0001-15880-1, 0001-15561-1, 0001-15732-1, 0001-15735-1, 0002-15735-1, 0001-15765-2, 0002-15765-1, 0003-15765-2, 0003-15810-0, 0002-15810-0, 0001-15830-3, 0002-15830-1, 0003-15830-0, 0001-15850-1, 0002-15850-0, 0003-15850-2	TCY	HPCC	10/14/11	HPCC SSC Pl. File #B0.4.8	K. Guntow	Limbach		8/21/12	HPCC SSC Pl. File #B0.4.8	MB	HPCC	8/21/12	COMPLETE
<b>4 9 Fuel and Lube System</b>																								
4	9	1			Service Station Equipment	Design Build Specifications - Division 11 - 11140 - Service Station Equipment	Section 15206 / Dwg #MQ-000 thru MQ-601, FQ-000 thru FQ-602 / NFPA 30, 31, 70, 77 / DCMR Title 20 / ASME B31.9	L. Kieper	SYSTRA	6/10/11	Submittal #0001-11140-0, 0001-11140-0, 0003-11140-2, 0001-11140-2, 0006-11140-1, 0007-11140-0, 0001-11140-0, 0001-11140-0, 0001-11140-0	TCY	HPCC	11/30/11	HPCC SSC Pl. File #B0.4.9	B. Dorsey	Jones & Frank		8/21/12	HPCC SSC Pl. File #B0.4.9	MB	HPCC	8/21/12	COMPLETE
4	9	2			Piping Systems and UST's	RFP - FQR133 - Plumbing Program Requirements - Section IX - Fueling System - Part C	Section 15206 / Dwg #MQ-000 thru MQ-601, FQ-000 thru FQ-602 / NFPA 30, 31, 70, 77 / DCMR Title 20 / ASME B31.9	L. Kieper	SYSTRA	6/10/11	Submittal #0001-15192-0, 0001-15192-1, 0002-15192-1, 0003-15192-1, 0004-15192-2, 0005-15192-0, 0008-15192-0, 0009-15192-0, 0010-15192-0	TCY	HPCC	11/30/11	HPCC SSC Pl. File #B0.4.9	B. Dorsey	Jones & Frank		8/21/12	HPCC SSC Pl. File #B0.4.9	MB	HPCC	8/21/12	COMPLETE
<b>4 10 Low Voltage Distribution System</b>																								
4	10	1			Basic Electrical Materials and Methods	Design Build Specifications - Division 16 - 16320/16435 - High/Low Voltage Switchgear	Sections 16050 / Dwg #ME-001 thru ME-615, FE-001 thru FE-606, E-002 thru E-601, WE-001 thru WE-607 / NFPA 70E, NEMA 250, NEMA 370, NEMA 400	C. Aza	Mona	6/10/11	Submittal #0001-16050-0, 0002-16050-0, 0003-16050-0	TCY	HPCC	6/21/11	HPCC SSC Pl. File #B0.4.10	C. Aza	Mona Electric Group		8/21/12	HPCC SSC Pl. File #B0.4.10	MB	HPCC	8/21/12	COMPLETE
4	10	2			Grounding and Bonding	Design Build Specifications - Division 16 - 16320/16435 - High/Low Voltage Switchgear	Sections 16060 / Dwg #ME-001 thru ME-615, FE-001 thru FE-606 / NEC Art. 250, ANSI/IEEE 80-2000, UL-467	C. Aza	Mona	6/10/11	Submittal #0002-16060-0	TCY	HPCC	8/1/11	HPCC SSC Pl. File #B0.4.10	C. Aza	Mona Electric Group		8/21/12	HPCC SSC Pl. File #B0.4.10	MB	HPCC	8/21/12	COMPLETE
4	10	3			Wire, Cable and Busways	Design Build Specifications - Division 16 - 16320/16435 - High/Low Voltage Switchgear	Sections 16120 / Dwg #ME-001 thru ME-615, FE-001 thru FE-606, E-002 thru E-601, WE-001 thru WE-607 / NEC, ICEA, ANSI, UL54	C. Aza	Mona	6/10/11	Submittal #0001-16435-0, 0002-16435-0	TCY	HPCC	6/21/11	HPCC SSC Pl. File #B0.4.10	C. Aza	Mona Electric Group		8/21/12	HPCC SSC Pl. File #B0.4.10	MB	HPCC	8/21/12	COMPLETE
4	10	4			Wire Connection Accessories	Design Build Specifications - Division 16 - 16320/16435 - High/Low Voltage Switchgear	Sections 16125 / Dwg #ME-001 thru ME-615, FE-001 thru FE-606, E-002 thru E-601, WE-001 thru WE-607 / NEC, ASTM, ANSI, UL	C. Aza	Mona	6/10/11	Submittal #0001-16125-1, 0002-16125-0, 0004-16125-0, 0003-16145-0, 0004-16145-0, 0005-16145-0, 0006-16145-0	TCY	HPCC	2/14/12	HPCC SSC Pl. File #B0.4.10	C. Aza	Mona Electric Group		8/21/12	HPCC SSC Pl. File #B0.4.10	MB	HPCC	8/21/12	COMPLETE
4	10	5			Rackways, Boxes and Cabinets	RFP - FQR133 - Electrical Program Requirements - Section III - Wire Management - Part B	Sections 16130 / Dwg #ME-001 thru ME-615, FE-001 thru FE-606, E-002 thru E-601, WE-001 thru WE-607 / NEC, ASTM, NEMA 250, UL	C. Aza	Mona	6/10/11	Submittal #0001-16130-2, 0002-16130-0, 0003-16130-0, 0004-16130-0, 0005-16130-0, 0006-16130-0, 0007-16130-0, 0009-16130-0, 0010-16130-1	TCY	HPCC	6/21/11	HPCC SSC Pl. File #B0.4.10	C. Aza	Mona Electric Group		8/21/12	HPCC SSC Pl. File #B0.4.10	MB	HPCC	8/21/12	COMPLETE

Safety/Security Certifiable Items Ref Date: 8/21/12			Rev: 2	Design Conformance Checklist			Installation & Construction Conformance Checklist			Testing & Inspection Conformance Checklist			Final Verification			Certifiable Items List Template HPCC Conformance: DSP WMA/TA Conformance: NOS WMA/TA Safe: RLF						
Level 3 - Items	Level 2 - Sub-Items	Level 1 - Item	Item Description	Design Criteria	Doc Ref	Verified By	Company Verified By	Date	Doc Ref	Verified By	Company Verified By	Date	Doc Ref	Verified By	Company Verified By	Date	Doc Ref	Verified By	Company Verified By	Date	Comments	
4	10	6	Low Voltage Switchgear and Switchboard	RFP - FQB133 - Electrical Program Requirements - Section IV - Wire Management - Part D / Section IV - Building Service & Distribution - F	Sections 16435 / Dwg RME-001 thru ME-615, FE-001 thru FE-606, E-002 thru E-601, WE-001 thru WE-607 / NEC, NEMA, PB2, ANS, UL, 891, ASTM B187, ANS/IEEE	C. Auza	Mona	6/10/11	Submittal #0001-16435-1, 0001-16425-0	TCY	HPCC	1/24/12	HPCC SSC Pl. File #80.4.10	C. Auza	Mona Electric Group	8/21/12	HPCC SSC Pl. File #80.4.10	MB	HPCC	8/21/12	COMPLETE	
4	10	7	Circuit Breakers, Panelboards and Load Centers	RFP - FQB133 - Electrical Program Requirements - Section II - Wire Management - Part F	Sections 16440 / Dwg RME-001 thru ME-615, FE-001 thru FE-606, E-002 thru E-601, WE-001 thru WE-607 / NEC, NEMA A81, PB1, ST20, 250, ANS 255.1, UL 50, 67, 158C, 489, 891, ASTM A276, B187, IEEE	C. Auza	Mona	6/10/11	Submittal #0001-16440-1	TCY	HPCC	11/28/11	HPCC SSC Pl. File #80.4.10	C. Auza	Mona Electric Group	8/21/12	HPCC SSC Pl. File #80.4.10	MB	HPCC	8/21/12	COMPLETE	
4	10	8	Transformers (Dry-Type)	RFP - FQB133 - Electrical Program Requirements - Section VI - Building Service and Distribution - Part C	Sections 16270 / Dwg RME-001 thru ME-615, FE-001 thru FE-606, E-002 thru E-601 / NEC, NEMA 571, ST20, 107, 250, ANS C57.12.30, C57.12.90, C57.15, C57.94, C57.113, C57.124, C57.11, IEEE C57.12.01, UL 506, 1561, 1562	C. Auza	Mona	6/10/11	Submittal #0001-16270-0	TCY	HPCC	2/3/12	HPCC SSC Pl. File #80.4.10	C. Auza	Mona Electric Group	8/21/12	HPCC SSC Pl. File #80.4.10	MB	HPCC	8/21/12	COMPLETE	
4	11		<b>High Voltage Distribution System</b>																			
4	11	1	Basic Electrical Materials and Methods	RFP - FQB133 - Electrical Program Requirements - Section V - Medium Voltage - Part A	Sections 16050 / Dwg RME-001 thru ME-615, FE-001 thru FE-606, WE-001 thru WE-607, E-002 thru E-601 / NECA-12006, NECA-1012006, NFA 70	C. Auza	Mona	6/6/11	Submittal #0001-16320-0, 0001-16425-0	TCY	HPCC	2/11/12	HPCC SSC Pl. File #80.4.11	C. Auza	Mona Electric Group	8/21/12	HPCC SSC Pl. File #80.4.11	MB	HPCC	8/21/12	COMPLETE	
4	11	2	Medium Voltage Cable	RFP - FQB133 - Electrical Program Requirements - Section V - Medium Voltage - Part A.5	Sections 16119 / Dwg RME-001 thru ME-615, FE-001 thru FE-606, WE-001 thru WE-607, E-002 thru E-601 / ANS1, ICSA, NEMA, ASTM, NESC and NEC	C. Auza	Mona	6/6/11	Submittal #0001-16119-0, 0003-11609-0, 0001-16320-0	TCY	HPCC	2/16/12	HPCC SSC Pl. File #80.4.11	C. Auza	Mona Electric Group	8/21/12	HPCC SSC Pl. File #80.4.11	MB	HPCC	8/21/12	COMPLETE	
4	11	3	Transformers (Oil-filled)	RFP - FQB133 - Electrical Program Requirements - Section VI - Building Service and Distribution - Part B	Sections 16270 / Dwg RME-001 thru ME-615, FE-001 thru FE-606, E-002 thru E-601 / NEC, NEMA- 571, ST20, 107, 250/ ASTM D1487/ ANS/IEEE: C57.12.00, C57.12.90, C57.12.91, C57.15, C57.94, C57.113, C57.124, C57.11/IEEE: C57.12.01/ UL: 506, 1561, 1562	C. Auza	Mona	6/6/11	Submittal #0001-16270-0, 0001-16270-0	TCY	HPCC	2/16/12	HPCC SSC Pl. File #80.4.11	C. Auza	Mona Electric Group	8/21/12	HPCC SSC Pl. File #80.4.11	MB	HPCC	8/21/12	COMPLETE	
4	11	4	High Voltage Switchgear	RFP - FQB133 - Electrical Program Requirements - Section VI - Building Service & Distribution - Part D	Sections 16320 / Dwg RME-001 thru ME-615, FE-001 thru FE-606, E-002 thru E-601 / NEC, NEMA- 96A, ANS: C37.62, 255.1, ANS/IEEE: C37.09, C37.20.2, C37.90, C37.11, C52.11 / IAH: 151	C. Auza	Mona	6/6/11	Submittal #0001-16319-0, 0001-16270-0	TCY	HPCC	2/16/12	HPCC SSC Pl. File #80.4.11	C. Auza	Mona Electric Group	8/21/12	HPCC SSC Pl. File #80.4.11	MB	HPCC	8/21/12	COMPLETE	
4	12		<b>Emergency Standby Generator System</b>																			
4	12	1	Basic Electrical Materials and Methods	Design Build Specifications - Division 16 - 16220 - Emergency Standby Generator System	Sections 16050 / Dwg RME-001 thru ME-615, FE-001 thru FE-606, WE-001 thru WE-607, E-002 thru E-601 / NECA-12006, NECA-1012006, NFA 70	C. Auza	Mona	6/10/11	Submittal #0001-16220-1	TCY	HPCC	2/27/12	HPCC SSC Pl. File #80.4.12	C. Auza	Mona Electric Group	8/21/12	HPCC SSC Pl. File #80.4.12	MB	HPCC	8/21/12	COMPLETE	
4	12	2	Grounding and Bonding	Design Build Specifications - Division 16 - 16220 - Emergency Standby Generator System	Sections 16060 / Dwg RME-001 thru ME-615, FE-001 thru FE-606, WE-001 thru WE-607, E-002 thru E-601 / NEC Art. 250, ANS/IEEE 80 2000, UL467	C. Auza	Mona	6/10/11	Submittal #0001-16220-1	TCY	HPCC	2/27/12	HPCC SSC Pl. File #80.4.12	C. Auza	Mona Electric Group	8/21/12	HPCC SSC Pl. File #80.4.12	MB	HPCC	8/21/12	COMPLETE	
4	12	3	Wire, Cable and Busways	Design Build Specifications - Division 16 - 16220 - Emergency Standby Generator System	Sections 16120 / Dwg RME-001 thru ME-615, FE-001 thru FE-606, WE-001 thru WE-607, E-002 thru E-601 / NEC, ICSA, ANS, UL 44	C. Auza	Mona	6/10/11	Submittal #0001-16220-1	TCY	HPCC	2/27/12	HPCC SSC Pl. File #80.4.12	C. Auza	Mona Electric Group	8/21/12	HPCC SSC Pl. File #80.4.12	MB	HPCC	8/21/12	COMPLETE	
4	12	4	Wire Connection Accessories	Design Build Specifications - Division 16 - 16220 - Emergency Standby Generator System	Sections 16125 / Dwg RME-001 thru ME-615, FE-001 thru FE-606, WE-001 thru WE-607, E-002 thru E-601 / NEC, ASTM, ANS, UL	C. Auza	Mona	6/10/11	Submittal #0001-16220-1	TCY	HPCC	2/27/12	HPCC SSC Pl. File #80.4.12	C. Auza	Mona Electric Group	8/21/12	HPCC SSC Pl. File #80.4.12	MB	HPCC	8/21/12	COMPLETE	
4	12	5	Emergency Standby Generator System	Design Build Specifications - Division 16 - 16220 - Emergency Standby Generator System	Sections 16220 / Dwg RME-001 thru ME-615, FE-001 thru FE-606, WE-001 thru WE-607, E-002 thru E-601 / NFA 70 and 37, NFA 110 Level 2 / MG1 / UL: 1236, ISO 9002 and ETL	C. Auza	Mona	6/10/11	Submittal #0001-16220-1, 0002-16620-0	TCY	HPCC	2/27/12	HPCC SSC Pl. File #80.4.12	C. Auza	Mona Electric Group	8/21/12	HPCC SSC Pl. File #80.4.12	MB	HPCC	8/21/12	COMPLETE	
4	13		<b>Uninterruptible Power Supply</b>																			
4	13	1	Uninterruptible Power Supply	RFP - FQB133 - Electrical Program Requirements - Section IV - Special Equipment - Part E	Sections 16260 / Dwg RME-001 thru ME-615, FE-001 thru FE-606, WE-001 thru WE-607, E-002 thru E-601 / NEC, NEMA, FE1, ANS: C39.1, ANS/NEMA: PB1, UL 50, ANS/AHA: 135.4, ASTM: B187-00	C. Auza	Mona	6/10/11	Submittal #0001-16220-1	TCY	HPCC	3/26/12	HPCC SSC Pl. File #80.4.13	C. Auza	Mona Electric Group	6/12/12	HPCC SSC Pl. File #80.4.13	MB	HPCC	8/21/12	COMPLETE	
4	14		<b>Lightning Protection</b>																			
4	14	1	Lightning Protection	RFP - FQB133 - Electrical Program Requirements - Section IV - Special Equipment - Part B	Sections 16670 / WE-133, ME-501 thru ME-502, FE-501 thru FE-502 / NFA 780 / UL-96A	C. Auza	Mona	6/10/2011	Submittal #0001-16670-1	TCY	HPCC	2/6/12	HPCC SSC Pl. File #80.4.14	C. Auza	Mona Electric Group	6/19/12	HPCC SSC Pl. File #80.4.14	MB	HPCC	6/29/12	COMPLETE	
4	15		<b>Comms - Fire and Intrusion Alarm System</b>																			
4	15	1	Telecomm Standard Specifications	RFP - FQB133 - Electrical Program Requirements - Section XIII - Communications and Security	Sections 16700 / FT-001 thru FT-609, MT-100 thru MT-617, WT-001 thru WT-609 / TIA/EIA, I-STD, BICSI-TDMM, NFA 70, NEC, FCC, UL, ANS, REA, ICSA, EIA, NEMA, IEEE	M. Romano/ C. Auza	FLSA / Mona	6/10/11	Submittal #0001-16700-0, 0001-16700-1	TCY	HPCC	12/12/11	HPCC SSC Pl. File #80.4.15	C. Auza	Mona Electric Group	8/21/12	HPCC SSC Pl. File #80.4.15	MB	HPCC	8/21/12	COMPLETE	
4	15	2	Comm System Submittals and Services	RFP - FQB133 - Electrical Program Requirements - Section XIII - Communications and Security	Sections 16706 / FT-001 thru FT-609, MT-100 thru MT-617, WT-001 thru WT-609	M. Romano/ C. Auza	FLSA / Mona	6/10/11	N/A	TCY	HPCC	12/12/11	HPCC SSC Pl. File #80.4.15	C. Auza	Mona Electric Group	8/21/12	HPCC SSC Pl. File #80.4.15	MB	HPCC	8/21/12	COMPLETE	
4	15	3	Comm System QA and Testing	RFP - FQB133 - Electrical Program Requirements - Section XIII - Communications and Security	Sections 16707 / FT-001 thru FT-609, MT-100 thru MT-617, WT-001 thru WT-609	M. Romano/ C. Auza	FLSA / Mona	6/10/11	N/A	TCY	HPCC	12/12/11	HPCC SSC Pl. File #80.4.15	C. Auza	Mona Electric Group	8/21/12	HPCC SSC Pl. File #80.4.15	MB	HPCC	8/21/12	COMPLETE	
4	15	4	Communications Grounding	RFP - FQB133 - Electrical Program Requirements - Section XIII - Communications and Security	Sections 16710 / FT-001 thru FT-609, MT-100 thru MT-617, WT-001 thru WT-609 / NFA 70	M. Romano/ C. Auza	FLSA / Mona	6/10/11	Submittal #0001-16710-0	TCY	HPCC	12/12/11	HPCC SSC Pl. File #80.4.15	C. Auza	Mona Electric Group	8/21/12	HPCC SSC Pl. File #80.4.15	MB	HPCC	8/21/12	COMPLETE	
4	15	5	Communications Electrical Power Dist.	RFP - FQB133 - Electrical Program Requirements - Section XIII - Communications and Security	Sections 16715 / FT-001 thru FT-609, MT-100 thru MT-617, WT-001 thru WT-609 / NEMA and NEC	M. Romano/ C. Auza	FLSA / Mona	6/10/11	Submittal #0001-16715-0	TCY	HPCC	12/12/11	HPCC SSC Pl. File #80.4.15	C. Auza	Mona Electric Group	8/21/12	HPCC SSC Pl. File #80.4.15	MB	HPCC	8/21/12	COMPLETE	
4	15	6	Comms - Fire and Intrusion Alarm System	RFP - FQB133 - Electrical Program Requirements - Section XIII - Communications and Security	Sections 16731 / FT-001 thru FT-609, MT-100 thru MT-617, WT-001 thru WT-609 / NEC Art. 780, UL Type FPLP, ASTM B3	M. Romano/ C. Auza	FLSA / Mona	6/10/11	Submittal #0001-16731-1, 0002-16731-0	TCY	HPCC	2/6/12	HPCC SSC Pl. File #80.4.15	C. Auza	Mona Electric Group	8/21/12	HPCC SSC Pl. File #80.4.15	MB	HPCC	8/21/12	COMPLETE	
4	15	7	Interface Criteria and Responsibilities	RFP - FQB133 - Electrical Program Requirements - Section XIII - Communications and Security	Sections 16886 / FT-001 thru FT-609, MT-100 thru MT-617, WT-001 thru WT-609 /	M. Romano/ C. Auza	FLSA / Mona	6/10/11	N/A	TCY	HPCC	2/6/12	HPCC SSC Pl. File #80.4.15	C. Auza	Mona Electric Group	8/21/12	HPCC SSC Pl. File #80.4.15	MB	HPCC	8/21/12	COMPLETE	







Safety/Security Certifiable Items List Date: 8/21/12 Rev: 2		Design Conformance Checklist				Installation & Construction Conformance Checklist				Testing & Inspection Conformance Checklist				Final Verification				Certifiable Items List Template HPC Conformance: DSP WMATA Conformance: NOS WMATA SAFE: RLF	
Item Description	Design Criteria	Doc Ref	Verified By	Company Verified By	Date	Doc Ref	Verified By	Company Verified By	Date	Doc Ref	Verified By	Company Verified By	Date	Doc Ref	Verified By	Company Verified By	Date	Comments	

Level 3 - Items  
 Level 2 - Sub-Items  
 Level 1 - Item  
 Item 1 - Sub-Item

\_\_\_\_\_  
 Verified By  
 MO, CO. MC

\_\_\_\_\_  
 \_\_\_\_\_  
 \_\_\_\_\_







# METRO PROJECT

## DAILY REPORT—LABOR, MATERIAL & EQUIPMENT

Order \_\_\_\_\_ for \_\_\_\_\_ Service \_\_\_\_\_ No. \_\_\_\_\_

Date \_\_\_\_\_ 20\_\_\_\_ Day [of week] \_\_\_\_\_

Contract No. \_\_\_\_\_

Contractor [Prime or Sub] \_\_\_\_\_

Contract Modification No. [or PCO #] \_\_\_\_\_

IMPORTANT: This form must be submitted not later than the day following date work was performed.

Report No. [Sequentially numbered] \_\_\_\_\_

Page [#] \_\_\_\_\_ of [#] \_\_\_\_\_

The following work was performed this date requiring use of the Labor Force, Materials, Equipment, Special Forces and Services listed hereon:

DESCRIPTION OF WORK PERFORMED:

[Specific description of work] \_\_\_\_\_  
 \_\_\_\_\_  
 \_\_\_\_\_

Certified Correct By \_\_\_\_\_ Date \_\_\_\_\_  
Contractor & Representative

LABOR				EQUIPMENT			
Name	Craft	Class	Hours	Make	Model	Description	Hours
[Labor Foreman]	[L]	[F]	OT ST [8]	[CAT]	[235]	[Backhoe]	[4/4 S*]
[Laborer-skilled]	[L]	[S]	OT ST [8]			[*Stand-by]	
[Laborer-skilled]	[L]	[S]	OT ST [8]				
[Laborer-unskilled]	[L]	[U]	OT ST [8]				
[Operator]	[OE]		OT ST [8]				
			OT ST				
			OT ST				
			OT ST				
			OT ST				
			OT ST				

### MATERIALS, SPECIAL FORCES AND SERVICES

Quantity	Unit	Description
		[Specified description of each item of material with attached invoices]

**For Engineer's Use**

Hours Worked Verified By \_\_\_\_\_

\_\_\_\_\_

Field Staff member

**APPROVED AS TO SUBSTANCE**

By \_\_\_\_\_ Date \_\_\_\_\_

Resident Engineer









Washington Metropolitan Area Transit Authority

# **PREVENTIVE MAINTENANCE INSPECTION**

for

**35kV AC  
WESTINGHOUSE LOAD BREAK  
INTERRUPTER SWITCH TYPE WLI  
INSTALLED AT C99 TP  
(for S&I SHOP DC POWER)  
728/1090 DAY INSPECTION**

# PMI



Washington Metropolitan Area Transit Authority

**SYSTEMS MAINTENANCE BRANCH**

PREVENTIVE MAINTENANCE INSTRUCTION (PMI)

**35kV AC  
WESTINGHOUSE LOAD BREAK  
INTERRUPTER SWITCH TYPE WLI  
INSTALLED AT C99 TP  
(for S&I SHOP DC POWER)  
728/1090 DAY INSPECTION**

REVISION NUMBER \_\_\_\_\_

REVISION DATE 9/28/2012

APPROVALS:

\_\_\_\_\_  
TSSM - POWER SUPERINTENDENT DATE

\_\_\_\_\_  
TIES - CENI DEPUTY CHIEF ENGINEER - POWER DATE

\_\_\_\_\_  
TSSM - GENERAL SUPERINTENDENT DATE

REVIEWED BY: E Rose

# WARNING

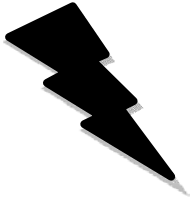

**Hazardous voltages and high speed moving parts may cause death, serious personal injury or equipment damage. Always follow Red Tag Procedures. De-energize the equipment before maintenance. Maintenance should be performed only by qualified personnel. Follow all safety instructions.**

# WARNING



**Failure to maintain the equipment could result in death, serious injury or equipment failure, and can prevent successful functioning of the connected apparatus.**

# WARNING



**Maintenance must be performed only by qualified persons as defined by the section “Qualified Person” in this procedure.**

## **QUALIFIED PERSON**

For the purpose of this Preventive Maintenance Inspection, a qualified person is person who is familiar with the installation, construction, operation, and maintenance of the equipment and the hazards involved. In addition, this person has the following qualifications:

1. Is trained and authorized to energize, de-energize, ground, tag and clear circuits and equipment in accordance with established procedures and safety practices.
2. Is trained in the proper care and use of protective equipment such as rubber gloves, hard hat, safety glasses and face shields and flash clothing in accordance with established safety practices.
3. Is trained in rendering first aid and CPR.
4. Is trained in the use and care of high voltage test equipment.

### **Suggested Reference Material for additional training purposes includes:**

OSHA STANDARDS 29CFR 1910 Occupational Safety and Health Standards  
1910 Subpart J General Environmental Controls - 1910.147 Lockout / Tagout  
1910 Subpart R – Special Industries 1910.269 Electric Power Generation, Transmission and Distribution

- 1910.269 (a) General
- 1910.269 (b) Medical services and first aid
- 1910.269 (c) Job briefing
- 1910.269 (d) Lockout/Tagout
- 1910.269 (e) Enclosed spaces
- 1910.269 (h) Ladders, platforms, step bolts, and manhole steps
- 1910.269 (i) Hand and portable power tools
- 1910.269 (k) materials handling and storage
- 1910.269 (l) Working on or near exposed energized parts
- 1910.269 (m) Deenergizing lines and equipment for employee protection
- 1910.269 (n) Grounding for the protection of employees
- 1910.269 (o) Testing and test facilities
- 1910.269 (t) Underground electrical installations
- 1910.269 (u) Substations
- 1910.269 (x) Definitions
- 1910.269 Appendix E Reference Documents



## **SUGGESTED ADDITIONAL SAFETY REFERENCES MATERIAL**

WMATA Metrorail Safety Rules and Procedures Handbook, SOP 28, SOP 39

ANSI/NFPA 70E – Standard for Electrical Safety In The Workplace, Article 130, Arc Flash Hazard Awareness, Analysis, Determination of Flash Protection Boundaries and Requirement for Personal Protection Equipment (PPE)

ANSI-C2/IEEE-C2 Section 43 - Minimum Approach Distance to Energized Parts

ASTM F496 - Standard Specification for In-Service Care of Insulating Gloves and Sleeves

ASTM F696 - Standard Specification for Leather Protectors for Rubber Insulating Gloves and Mittens

ASTM F855 - Standard Specification for Temporary Grounding Systems to Be Used on De-Energized Electrical Power Lines and Equipment

National Institute for Occupational Safety and Health (NIOSH), Electrical Safety Training Booklet, free down load at [www.cdc.gov/niosh/docs/2002-123/2002-123a.html](http://www.cdc.gov/niosh/docs/2002-123/2002-123a.html)

## **SUGGESTED TECHNICAL REFERENCE MATERIAL**

Westinghouse	Load Break Interrupter Switch Type WLI Installation, Operation and Maintenance Instruction Booklet
NETA	Maintenance Testing Specifications For Electrical Power Distribution Equipment
ANSI/IEEE Std. 100	IEEE Standard Dictionary of Electrical and Electronics Terms
ANSI/IEEE Std. 902	Guide for Maintenance, Operation and Safety of Industrial and Commercial Power Systems
ANSI/NFPA 70B	Recommended Practice for Electric Equipment Maintenance
ANSI/IEEE Std. 902	Guide for Maintenance, Operation and Safety of Industrial and Commercial Power Systems
NEMA B4	Guidelines for Inspection and Preventive Maintenance of Circuit Breakers in Commercial and Industrial Applications

## 35 kV AC WESTINGHOUSE NO-LOAD INTERRUPTER SWITCH TYPE WLI

### 1.1 INTRODUCTION

1. Prior to performing this PMI procedure conduct a job briefing outlining any safety concerns and potential hazards. Inform the MOC of procedure to be performed. Have on hand a copy of this procedure along with the required PMI Data Sheets, the required equipment listed in 3.0 of this procedure, a copy of the specific Manufacturer's Maintenance Manual 31-935, the electrical schematics and wiring diagrams of C99 TPSS.
2. This PMI is written for the two 34.5KV Westinghouse type WLI Load Interrupter Switches installed in the WMATA C99 TP for C99 S&I shop TB in a duplex switchgear assembly configuration. (Fig. 1, 2)
3. The C99 TPSS duplex switchgear configuration consist of two Westinghouse load Interrupter switches 35KV, type WLI with a common load side bus to feed Rectifier transformer # 3. Rectifier transformer breakers 11 and 12 supply 34.5KV to the two switches. Key interlocks A1, A3 and A4 are supplied to prevent paralleling the incoming sources, and to prevent opening the front door of each vertical section containing one of the two switches unless both rectifier transformer breakers and both switches are locked open.
4. C99 TP Westinghouse WLI switches are **NO-LOAD** switches, and are Kirk Key interlocked to each other and to the associated rectifier transformer breaker to prevent switches to be open under load and to prevent both switches from being closed at the same time. Under no circumstances both switches should be closed at the time to supply power to the rectifier #3 feeding the S&I shop TB.
5. Performance of this PMI will require a scheduled Red Tag power outage for C99TP Breakers 11, 12, 21, 22, 23 and the entire Alexandria S&I Shop TB Substation. Refer to the attached Alexandria Yard C99 TP single line drawing (Figure 1), to be used only for this preventive maintenance procedure.
6. The purpose of performing this PMI is to reduce hazards to life and property that can result from failure or malfunction of electrical systems and equipment. Effective PMI can aid in reducing unscheduled outages by identifying, through regular service intervals, equipment conditions and irregularities which can cause malfunctions or equipment failure.
7. PMI of the Westinghouse 34.5 kV AC load interrupter switch type WLI will include an inspection, cleaning, checking and an overall evaluation of the cubicle and the load break switch and associated components and high voltage fuses (if applicable). As necessary, adjustments should be made to insure operation and/or alignments are within manufacturer's stated tolerances.



Fig. 1 WESTINGHOUSE 34.5KV LOAD INTERRUPTER SWITCH TYPE WLI

**Westinghouse** 

**WLI Load Interrupter Switchgear**

Built on Order # **BA-58000CNL**  
 Drawing # **CN-796A57A02**

Switch Style **4893A0IG06**

KV Rating		Ampere Rating	
Nominal	34.5	Continuous	600
Maximum	38.0	Interrupting	600
B.I.L.	150	Momentary	40,000
		Fault Close	30,000

**Westinghouse Electric Corp.  
 Distribution Equipment Div.  
 Cincinnati, Ohio U.S.A.**

Fig. 2 Westinghouse WLI Load Interrupter Switch

## 2.1 SAFETY

1. Read and understand these instructions before attempting any assembly, operation, or maintenance of the switch. Do not attempt to operate a connected WLI switch until the rectifier transformer breakers 11 and 12 have been open and rack out, and switches are disconnected from all electric power sources.
2. Do not attempt to close both WLI switches at the same time except as part of an interlock maintenance check when all power has been removed from the line and load sides of the switchgear.
3. All personnel shall follow all the accepted safety practices and procedures while performing this PMI and exercise appropriate caution. Warnings are included to alert the technician to tests and measurements that warrant special care and attention.
4. Ground leads or their equivalent should be attached to both sides of the switch. Make certain that safety grounds are properly in-place on both the jaw and hinge sides of the switch before working inside the switch cubicle or on the switch.
5. There are several interlocks on the switches. Under **NO** circumstances should they be made inoperative when the switch is *in service*, as they are designed to provide personnel protection as well as electric system operational integrity.
6. Never energize the switch without the arc chutes and barriers installed in place.
7. Make sure all safety interlocks are working properly prior to energizing.
8. Never install fuses with a rating greater than that listed on the switch nameplate.

# CAUTION



All test equipment used must have been provided by WMATA and must carry current test certification.

# CAUTION

**DO NOT REMOVE COVERS OR OPEN DOORS OR WORK ON EQUIPMENT UNLESS POWER HAS BEEN TURNED OFF AND ALL CIRCUITS DE-ENERGIZED AND/OR PROPERLY DISCONNECTED/GROUNDED.**

**DISCONNECT, DE-ENERGIZE, LOCK-OUT AND PROPERLY GROUND CIRCUIT(S) BEFORE WORKING ON EQUIPMENT.**

**USE PROPER SAFETY PRECAUTIONS WHEN WORKING ON THIS EQUIPMENT.**

**SOME PROCEDURES REQUIRE WORK AROUND MOVING PARTS, e.g. OPERATING HANDLE, CHAIN AND SPROCKET, STORED ENERGY MECHANISM, etc. TO AVOID PERSONAL INJURY, EXTREME CAUTION MUST BE EXERCISED TO STAY CLEAR (HEAD, HANDS, ETC.) OF THE PATH OF THESE MOVING PARTS AND SWITCH CONTACTS WHILE PERFORMING THIS PMI.**

## **3.1 EQUIPMENT**

1. Switching suit with rubber gloves (with clean leather protectors)
2. Insulated fuse pullers
3. Digital multi meter
4. Flashlight
5. Specific Manufacturer's technical manual
6. Lint-free rags or cleaning wipes
7. Vacuum and non-conductive hose
8. Scotch-Brite pads / file
9. Cleaning solvent
10. Sand paper and paint
11. Micro-ohm meter
12. Lubricating grease, D50H15 or equivalent (R91-50-0015)
13. Contact grease, D50H47, Westinghouse Graphite grease 53701AN or equivalent (R91-50-0014)
14. Light machine oil/Spray lubricant
15. Standard hand tools and ruler
16. 2/0 AWG Trifurcated Safety Ground Sets (Two Sets)

18. 2/0 AWG Safety Grounding Jumpers (Two Sets)
19. PMI calibration stickers
20. High Voltage Gloves

#### 4.1 SWITCHGEAR DE-ENERGIZATION

Prior to beginning the PMI, switching procedure and operational verification listed below should be performed. Complete the PMI Data Sheet tabulation as you progress through this procedure.

The switches are **NO LOAD** switches, both rectifier transformer breakers must be open and racked out; key interlocks are provided so that both interrupter switches must be open and locked before either enclosure door can be open. These built-in features are designed to reduce hazards and to provide proper operating sequences. Proper operation of these interlocks is essential for safety and their proper operation should be verified during the execution of this PMI. **Both load interrupter switches MUST be maintained under the same red tag outage.** (SEE C99 TP SUBSTATION ONE-LINE)

1. Verify that both incoming breakers are closed, the tie breaker open, all rectifier transformer breakers are closed, all rectifiers are running, all cathode breakers closed, all feeder breakers closed, and only one (1) Load Interrupter Switch is closed ( Same switch will be closed back after the maintenance is completed).
2. Request permission from MOC and the yard tower to start the red tag switching.
3. Coordinate the switching with Alexandria S&I Shop CMNT Supervisor.
4. De-energize and rack out Rectifier Transformer Breakers # 11 and 12, remove Kirk Keys and insert into correspondent locks A3 and A4 on the Load Interrupter Switches (Fig. 3A, B, C, locks are marked with permanent marker).
5. Rack out cathode breakers 21, 22, and 23.
6. Turn and unlock A3 or A4 lock on the “**closed**” interrupter switch and pull the handle to the “open” position.
7. Turn the A1 key to lock both Interrupter switches to the “open” position.
8. Verify that rectifier transformer breaker # 14 is closed and all track feeder breakers are closed.
9. Proceed with the PMI after red tag has been issued.

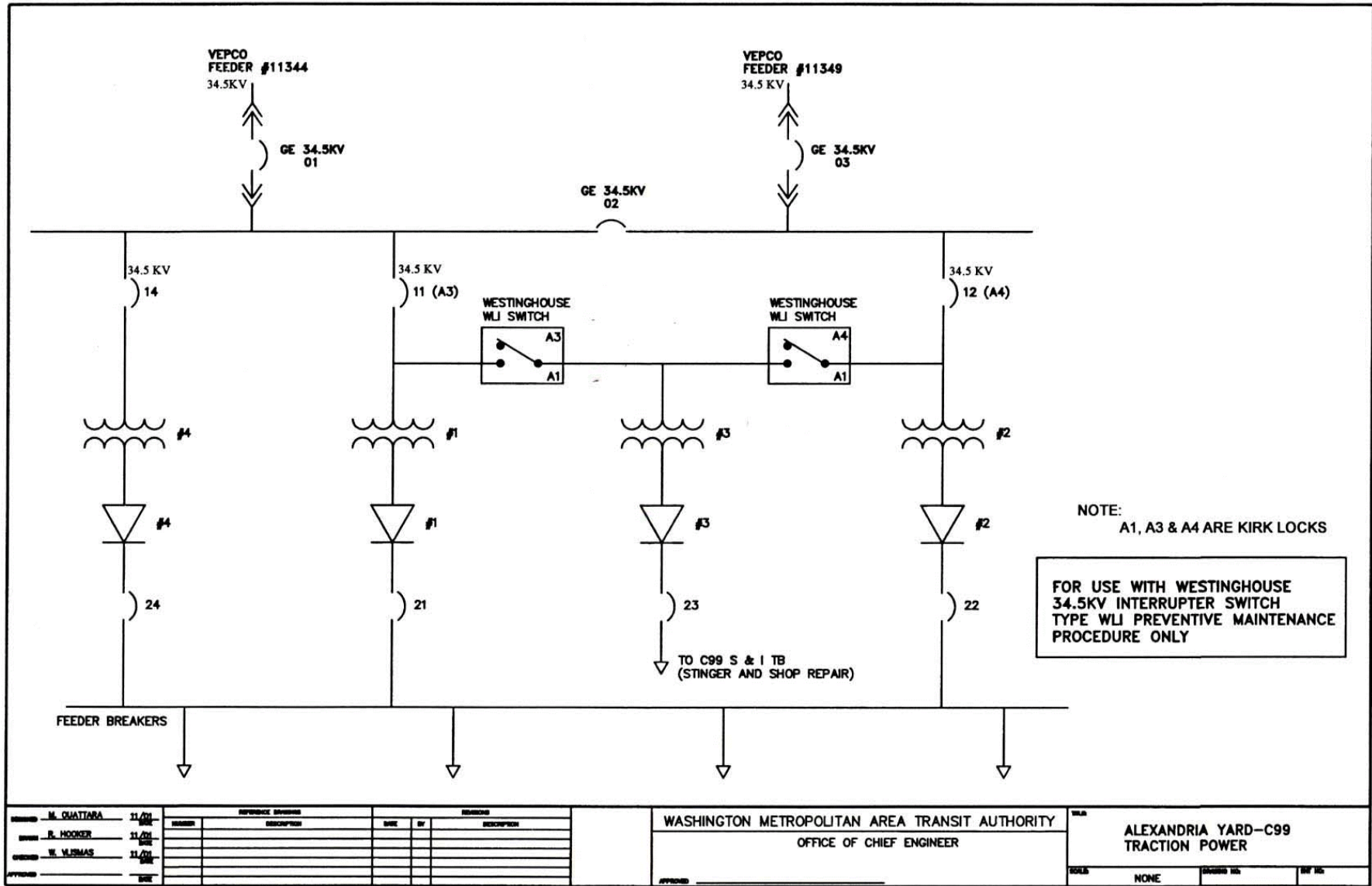

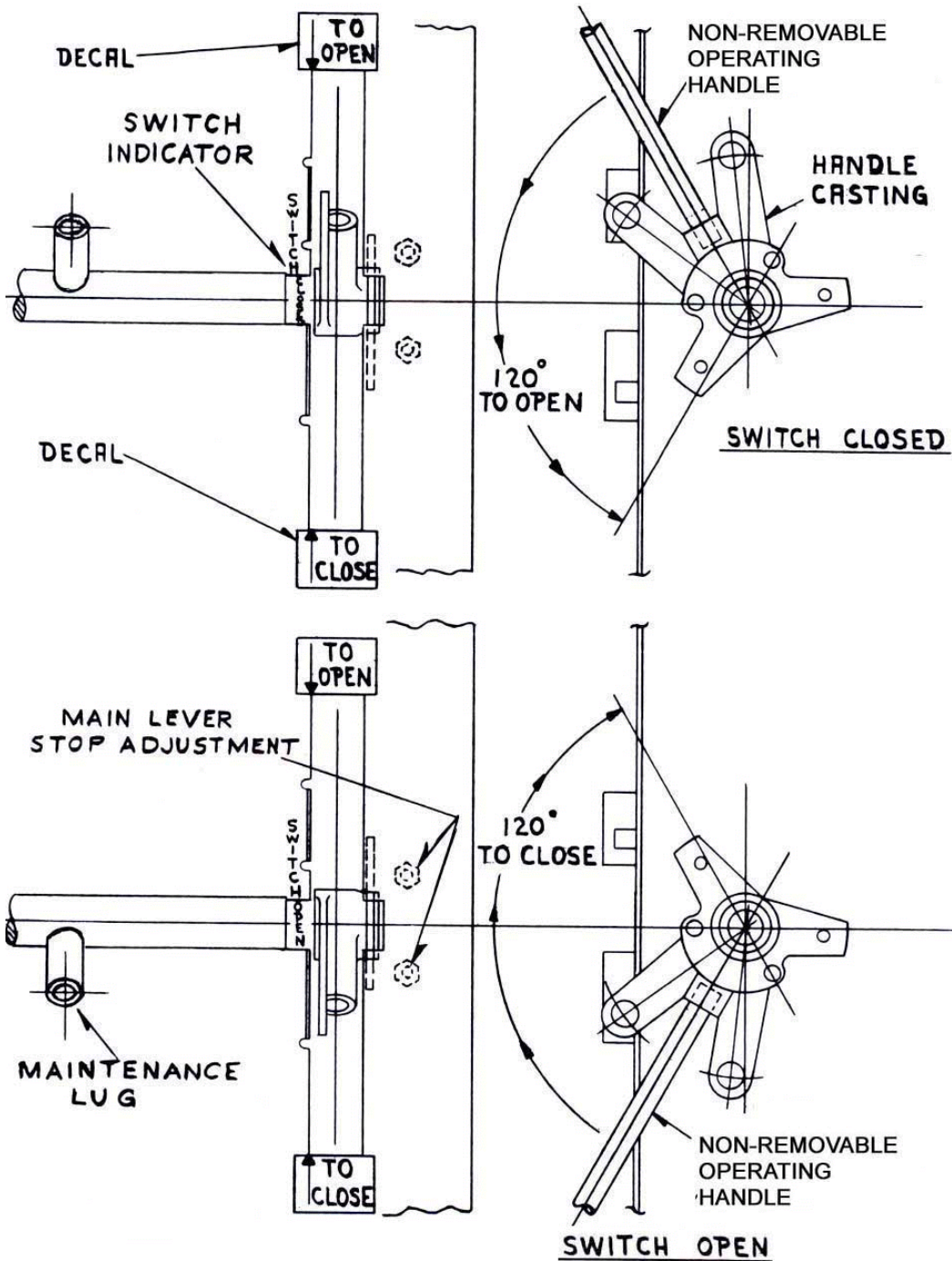



Fig. 3A WLI SWITCH IN OPEN POSITION  
(With non removable operating handle)



Fig. 3B WLI SWITCH IN CLOSED POSITION  
( with removable slow close handle on the left)



WESTINGHOUSE WLI LOAD INTERRUPTER SWITCH  
 Fig. 4 SWITCH OPERATION

## 5.0 SWITCH GROUNDING MECHANISM

The main blade mechanism is operated by a compression spring charged manually by rod connected to the switch shaft. To close the switch, a non-removable handle is extended and then rotated through an angle of 120°. This charges the compression spring and as the spring lever goes over toggle, the energy is transferred to the switch shaft which snaps the switch closed. (Fig. 4)

(Fig. 4, 5 and 6) On opening of the switch, the main blades open first which shunts the current through the spring loaded flicker blades. Further travel of the main blades causes the flicker blades to snap out of their contacts fingers arcs are draws within the De-ion arc chute.

After opening the switches and before opening doors, use viewing window to insure that all three switch blades are disengaged. If necessary, use a flashlight to verify all three contacts are open. Hot stick (34.5 KV AC) and Install grounds on the hinge side of the OPEN load interrupter switch. NOTE: You may also install additional grounds on the fuses (if provided) in the lower compartment which are in series with the disconnect switch and on the jaw side of the OPEN switch, at your discretion.

De-energize all AC and DC control power to the high voltage interrupter switch enclosure by opening control power disconnect switches and/or removing control power fuses, and verify that any and all potential back feed sources (motors, generators, control/potential/power transformers, cubicle heater supplies, etc.) have been properly isolated and safely grounded

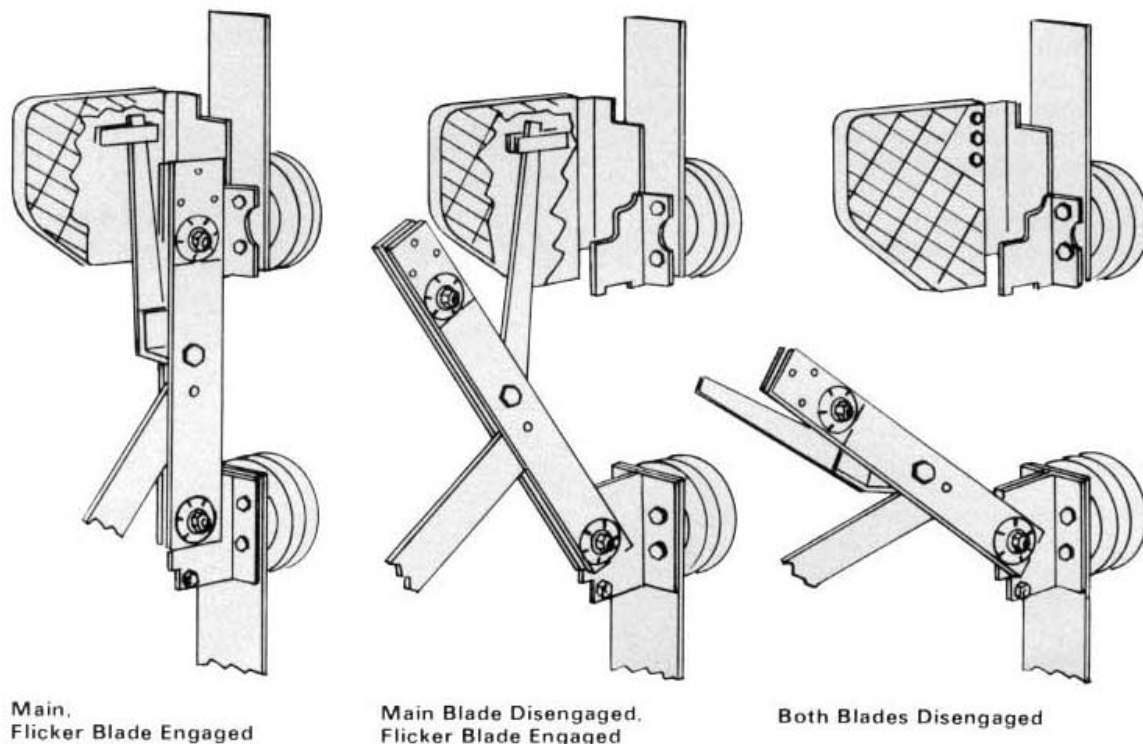

**Fig. 5 SWITCH MECHANISM**

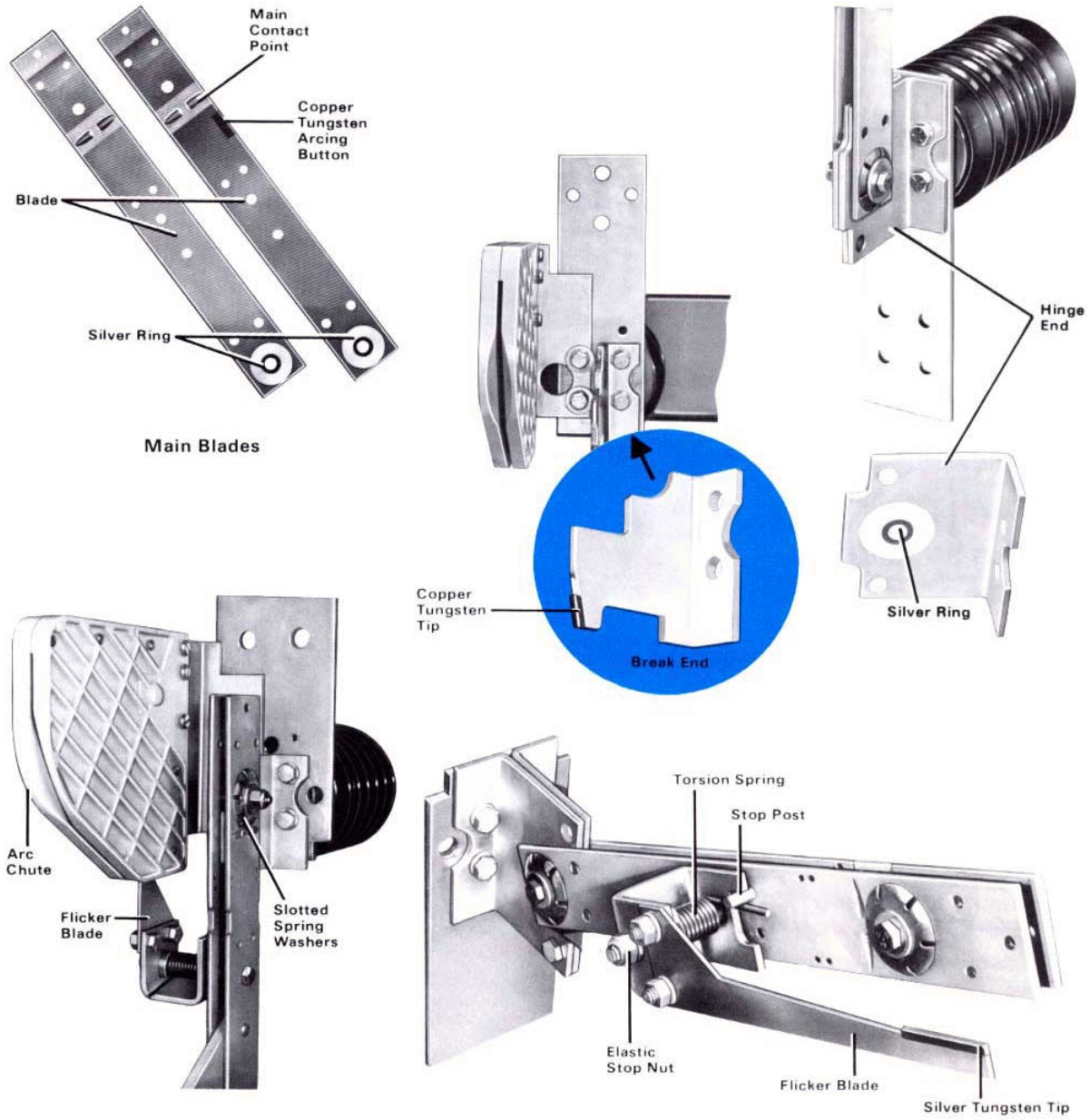

**Fig. 6 WLI CONTACTS ASSEMBLY**

## 6.1 CUBICLE PROCEDURE

1. Open BOTH switch compartments, Re-verify that all required grounds have been installed. Thoroughly clean the interior of all compartments, including all interior devices, current carrying components, switch operating arms, insulators, barrier boards, cubicle heaters, instruments, etc. of all dust, dirt and particles.
2. Inspect switches internally and externally for any sign of rust or corrosion. Any rust or corrosion shall be eliminated at once by sanding and touch up painting, unless the condition is severe or extensive enough to justify taking out a FSR number.
3. Check buses, Cables and connections for evidence of overheating or weakening of the insulation.
4. Inspect for loose hardware and any sign of loose/missing electrical and mechanical connections in and around the cubicle. Check anchor and structural nuts and bolts, tighten as necessary. Inspect for damaged, bent, or twisted door and compartment covers. Inspect door handles, locking bars and mechanism. Check any door interlocks, including keyed interlocks and associated locking bolts, and other mechanical mating parts for positive operation (visual check).
5. Check to see that all heaters are energized and operating.
6. Report any conditions which appear unsafe.

## 7.1 NO-LOAD BREAK SWITCH ASSEMBLY (Fig. 5, 6)

# WARNING

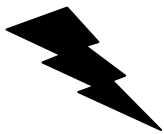

**AFTER OPENING OPERATION WAIT AT LEAST 30 SECONDS BEFORE CLOSING SWITCH. THIS ALLOWS BLADE VIBRATIONS TO DAMPEN AND DIMINISHES DAMAGING OF THE CHUTES**

1. Verify that all insulators and other insulation (e.g., barrier boards, operating mechanism connecting links), and all insulated and current carrying parts have been thoroughly cleaned of all dust, dirt, soot, grease and particles. Carefully examine the insulators and other insulation for treeing, tracking, cracks and discoloration. Pay special attention to areas where the bus and/or conductor passes through an insulator or is near a barrier.

2. Check the main blades contact pieces and the leading edges of the flicker blades for arc erosion (Fig.6). Inspect buses and other current carrying parts for discoloration or other evidence of overheating. Inspect arc chute sides and replace them if they are damaged. Check flicker blade contacts. If damage is less than half of the contacting surfaces, use a few light strokes of a fine file to clean up the arcing contacts. **Warning:** Do not attempt to file out the flicker arcing contacts pit marks, DO NOT USE abrasive material for cleaning (small bits of abrasive material may cause the contacts to overheat or even weld during fault).
3. Open and close the switch several time to clean the main contact. **Warning:** DO NOT FILE the main current carrying contacts. The main blade and hinge assembly together with the breaker jaw should be replaced if evidence of excessive burning over half of the contacting surfaces.
4. Check the engagement of the flicker blades by closing the switch. Main and flicker blades should be in proper alignment with the jaws and arc chute openings respectively. Replace worn or damaged parts of the flicker blade assembly.

## WARNING

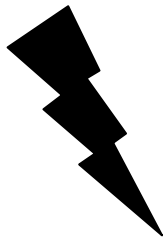

**DURING A SLOW CLOSE OR OPEN OPERATION, THE MECHANISM OPERATING SPRING IS BEING CHARGED AND WILL TEND TO RETURN THE SWITCH TO ITS INITIAL POSITION. THEREFORE, CARE MUST BE EXERCISED TO HOLD THE MAINTENANCE HANDLE FIRMLY UNTIL THE SPRING ENERGY IS DISCHARGED AND THE SWITCH IS RETURNED TO ITS INITIAL POSITION TO AVOID BODILY INJURY.**

5. Slowly open the switch. The flickers should remain engaged in their contact fingers while the main breaker is open. When the main blades clear the break jaw, they will hit a stop on the flicker blade brackets and start the flicker blades out of their contact fingers. The blade will then nap open from the forces in their charged torsion springs.
6. Close and Open the de-energized switch at least three times to check the performance of the operating mechanism.

### **8.1 NO-LOAD BREAK SWITCH ASSEMBLY ALIGNMENT PROCEDURE (Fig. 5, 6, 7)**

(The following alignments are not required if the above inspection is satisfactory, check alignment after replacing any part)

1. Insulator Alignment

All three lower insulators should be loosened and moved to the center line of the mounting holes in the support channel which is part of the switch frame.

All three Upper insulators should be placed vertically above the lower insulators on their support channel.

2. Main Blade Alignment (Fig. 7)

Loosen the four hinge terminal bolts on the top of the lower insulator. Loosen the two break jaw terminal bolts on top of the upper insulators. Slowly close the switch and hold it in the close position with the maintenance handle. Tighten up the bolts on both the hinge and jaw terminals. The upper spacer of the main blades should rest from 0.12 to 0.19 inch above the bottom of the depressions in the angular switch jaw.

3. Open Gap Adjustment (Fig. 7,)

With the switch in open position, the distance between the nearest point of the jaw to the main blades should be 6.38 to 6.62 inches. The upper bolt (Fig. 7, \*), bolt "B" on the front of L-shaped bearing support bracket adjust the open gap distance.

4. Flicker Blades and Arc Chute Adjustment (Fig. 6)

Loosen the two arc chute mounting bolt of each pole. Adjust the arc chute so that its opening is parallel to the main blade. Slowly close the switch and check that the flicker blade is in line with the arc chute opening.

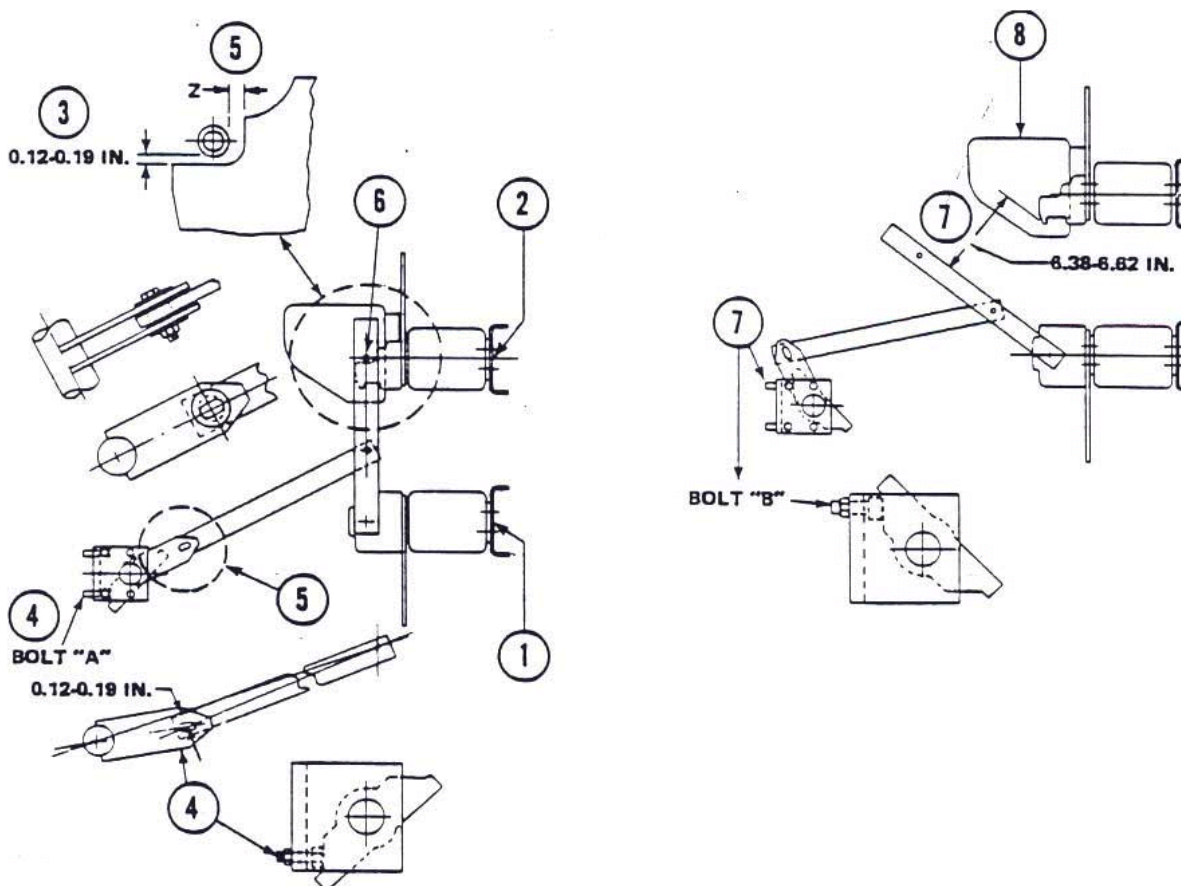

- 1 Lower insulators to be on center line of channel slots.
- 2 Upper insulators to be vertically above lower insulators.
- 3 Adjust upper insulators to give gap stting shown.
- 4 Set lower bolt, Bolt "A" to give overtoggle dimension shown.
- 5 Set dimension "Z" to 0.25 inch by extending drive rods.  
Tighten clamping hardware to 35-40 ft.lbs.
- 6 Break jaw contact bolt must not turn with the switch in closed position. It can turn in open position.
- 7 Set open gap to dimensionshown by adjusting bolt "B".
- 8 Align arc chute with flicker blade.

Fig. 7 ALIGNMENT AND INSPECTION GUIDE



## 9 **TESTING**

### Contact Resistance Testing

1. CLOSE the switch and use a micro-ohm meter to measure the contact resistance of each phase between the line and load terminal pads. Record readings on the Contact Resistance Tests PMI Data Sheet. If the values seem high (over 100 to 150 micro-ohms), visually check the blade wipe to insure proper contact. Open and close the switch a few times and recheck the contact resistance. If the values continue to be high, note in the Remarks section of the Data Sheet and take out a FSR as contact adjustments may be required, which is outside the scope of this PMI. Also note any readings greater than 25% of the lowest recorded resistance.

## 10. **GENERAL SWITCH MAINTENANCE AND LUBRICATION**

1. After completing the Inspection, Adjustments and Tests above, the switch and mechanism should again be thoroughly inspected to verify that there are no loose nuts or bolts, wiring, or damaged parts. All bearing, cam, roller and latch surfaces should be visually rechecked for evidence of damage or excessive wear.
2. Recheck the insulation (porcelain, barriers, glass reinforced plastic, etc.) to insure that their surfaces are clean and are not damaged.
3. The switch requires only moderate lubrication. The recommended lubrication details are itemized below:

<b>Recommended Lubrication</b>	
Main contacts	Wipe clean and apply a light coat of contact grease, D50H47 or equivalent , wipe off excess grease.
Contact portions between the blade and hinge, break jaw including arcing tip	DO NOT LUBRICATE.
Mechanism parts, bearing plates and points, sliding surfaces, pins, etc.	If grease has become oxidized (hardened or darkened), wipe clean and apply a light coat of white lubrication grease (D50H15).
Operating mechanism	Lubricate very sparingly with light machine oil, if necessary.

4. Operate the switch a few times to be sure that opening and closing operations are crisp and snappy. Verify that there is no excessive binding or friction, and that the switch moves to the fully opened and fully closed position.

## 11. RESTORATION TO NORMAL SERVICE

# WARNING



**AFTER OPENING OPERATION WAIT AT LEAST 30 SECONDS BEFORE CLOSING SWITCH. THIS ALLOWS BLADE VIBRATIONS TO DAMPEN AND DIMINISHES DAMAGING OF THE CHUTES**

1. Remove all installed grounds. Verify that all arc chutes, barriers and panels are properly in place. Restore all AC and DC control power to the cubicle (if applicable).
2. Perform an operational test to verify that ALL interlocks function properly. Perform the operational steps that would be “normal” to safely and properly **OPEN** and **CLOSE** the switch, and verify that the interlocks force the proper sequence of operation.
3. Notify the MOC that the PMI is complete and the station is ready to be normalized. Clear all Red Tags and remove all block tags.
4. Notify the Alexandria Yard Tower Supervisor and the S&I Shop CMNT-Supervisor that shop power is ready to be restored and request a “Shop Power” announcement. **Do not proceed further until the “Shop Power” announcement has been made and clearance to proceed has been given by the Tower Supervisor, the CMNT-Supervisor and the MOC.**
5. Close the switch that was initially closed in section 4.0, leave the other switch open.
6. Rack cathode breakers 21, 22 and 23 in the connect position.
7. Rack rectifier transformer breakers 11 and 12 in connected position and close the breakers. Verify that cathode breakers 21, 22, and 23 are closed and 750 VDC is being supplied by all three (4) rectifiers.
8. Notify the MOC, Alexandria Yard Tower Supervisor and Shady Grove CMNT Supervisor that 750 VDC Shop Power has been restored to normal.

## 12 PMI DATA SHEET

Fill in all “fill-in-the-blanks” data and answer all questions on PMI Data Sheet.  
**Note discrepancies** in Remarks if adjustments or minor repairs did not correct the deficiency.



### PMI CHECK SHEET

#### WESTINGHOUSE TYPE WLI 34.5KV LOAD INTERRUPTER SWITCHES: C99TP

NOTE: Place a check mark ( ) in appropriate column. If checkmark is placed in "No" column, note as comment in Remarks.

Date: \_\_\_\_\_

GENERAL ITEMS:				
1.0	Job Briefing Conducted, MOC Informed of Procedure, Instruction Manuals, Drawings and Schematics Available.	Yes	<input type="checkbox"/>	No <input type="checkbox"/>
2.0	Safety and Operations Requirements Reviewed, Safety Equipment and PPE Available and Being Used.	Yes	<input type="checkbox"/>	No <input type="checkbox"/>
3.0	Tools and Materials Available.	Yes	<input type="checkbox"/>	No <input type="checkbox"/>
4.0	Outage Coordinated with MOC, RTRA, CMNT. Breakers 11, 12, 21, 22, 23 De-energized, racked out Tested and Grounded.	Yes	<input type="checkbox"/>	No <input type="checkbox"/>
PMI INSPECTION ITEMS :		BREAKER 11 SWITCH		BREAKER 12 SWITCH
Record Switch Serial Number		Serial #: _____		Serial #: _____
Record Switch Nameplate Rating (Volts, Continuous Amps)		kV _____		kV _____
		Amps _____		
7.0 (If Applicable)		Manuf. _____		Manuf. _____
Record Fuse Nameplate Ratings:		Model/Class _____		Model/Class _____
Do Switch Nameplate Ratings Match		kV _____		
Fuse Nameplate Ratings?	Yes <input type="checkbox"/>	No	<input type="checkbox"/>	
Do Spare Fuses' Ratings Match The Switch?	Yes <input type="checkbox"/>	No	<input type="checkbox"/>	
Are All Fuses Same Manufacturer?	Yes <input type="checkbox"/>	No	<input type="checkbox"/>	
Number of Spare Fuses: _____		Continuous Amps _____		
		Interrupting Amps _____		
6.0-10.0	Performed Inspection, Cleaning, Contact Checks & Operational Checks	Yes	<input type="checkbox"/>	No <input type="checkbox"/>
9.0	Switch Alignment	Yes	<input type="checkbox"/>	No <input type="checkbox"/>
10.0	Cubicle, Switchgear Inspection Performed	Yes	<input type="checkbox"/>	No <input type="checkbox"/>
10.0	Switch Contact Resistance Tested. Results Recorded On Test Record	Yes	<input type="checkbox"/>	No <input type="checkbox"/>
11.0	General Switch Maintenance, Lubrication and Interlock Checks Completed	Yes	<input type="checkbox"/>	No <input type="checkbox"/>
12.0	All Substation Equipment Restored to Normal Service.	Yes	<input type="checkbox"/>	No <input type="checkbox"/>
13.0	All Maintenance Data Recorded on PMI Check Sheet,	Yes	<input type="checkbox"/>	No <input type="checkbox"/>

REMARKS \_\_\_\_\_

TECHNICIANS: \_\_\_\_\_ CALLS: \_\_\_\_\_ DATE: \_\_\_\_\_

SUPERVISOR: \_\_\_\_\_ CALLS: \_\_\_\_\_ DATE: \_\_\_\_\_



**PMI DATA SHEET  
NO-LOAD INTERRUPTER SWITCH  
CONTACT RESISTANCE TEST**

**NOTES: Fill in all relevant data fields, below. If the equipment fails a specific test, note as comment in remarks.  
Perform contact resistance test.**

<b>LOCATION:</b>		<b>DATE:</b>			<b>CUBICLE MANUFACTURER:</b>		
<b>EQUIPMENT TYPE:</b>		<b>VOLTAGE RATING (KV):</b>			<b>AMPS:</b>		
<b>MODEL NO:</b>		<b>SERIAL NO:</b>			<b>VEPCO FEEDER NO:</b>		
<b>WMATA Cubicle Designation</b>	<b>Serial Number</b>	<b><u>Contact Resistance Test</u></b> (Micro-ohms)			<b><u>Contact Resistance Test</u></b> (Micro-ohms)		
		AØ	BØ	CØ	AØ	BØ	CØ

REMARKS \_\_\_\_\_

TECHNICIANS: \_\_\_\_\_ CALLS: \_\_\_\_\_ DATE: \_\_\_\_\_

SUPERVISOR: \_\_\_\_\_ CALLS: \_\_\_\_\_ DATE: \_\_\_\_\_